

48A Flux AC Charger

User Manual



IMPORTANT SAFETY INSTRUCTIONS RELATED TO RISK OF FIRE OR ELECTRIC SHOCK

WARNING: When working with electrical products, basic precautions should always be followed. This manual contains important instructions for ECA-NC3202S-XYZC, ECA-NC4002S-XYZC and ECA-NC4802S-XYZC models, needs to be observed during installing, operating and maintaining. Before using this product, please read all instructions:

1. Use of this device around children should be done under supervision.
2. Do not stick your fingers into the EV connector.
3. Do not use this product if the flexible power cord or scooter cable is frayed, has torn insulation, or has any other damage.
4. Do not use this product if the housing or EV connector is broken, cracked, opened, or otherwise damaged.
5. Indicate the ambient temperature grade: -30°C to 50°C .
6. Note the following or similar: "To reduce the risk of fire, connect to a circuit providing the following function". @ampere's maximum branch circuit overcurrent protection shall be in accordance with the National Electrical Code ANSI/NFPA 70, and Canadian Electrical Code Part 1 C22.1.

Note(@).

Model	Required Service Panel Breaker
ECA-NC3202S-XYZC	40 A
ECA-NC4002S-XYZC	50 A
ECA-NC4802S-XYZC	60 A

SAVE THESE INSTRUCTIONS

Contents

Abbreviations.....	4
Safety Instructions.....	4
Compliance with Standard.....	5
Safety Standard.....	5
Charging Modes and Connections.....	5
1. Product Information.....	6
1.1. Type.....	6
1.1.1. Shape and Size.....	6
1.1.2. Block Diagram.....	7
1.1.3. Model Definition.....	8
1.2. Empty Seat.....	9
1.3. Specifications.....	10
2. Operation.....	12
2.1 Switch.....	12
2.2 About the Interface.....	12
3 Features.....	14
3.1 User Interface & Control.....	14
3.2 Configure WiFi Network (Currently no APP).....	17
3.3 Operation Guide.....	20
3.4 Troubleshooting.....	22
4 Installation.....	23
4.1 Labels.....	23
4.2 Packaging.....	23
4.2.1 Packing List.....	22
4.2.2 Check and Confirm.....	24
4.3 Preparation.....	24
4.4 Installation Steps.....	25
4.4.1 Wall Mount.....	25
4.4.2 Pedestal Mount.....	27
4.5 Grounding Instructions.....	30
4.6 Maintenance.....	30
Warranty Agreement.....	31

ABBREVIATIONS

S/N	Abbreviations	Description
1	EV/PHEV	Electric vehicles, either BEV (battery electric vehicles) or PHEV (plug-in hybrid electric vehicles)
2	EVSE	Electric Vehicle Supply Equipment
3	KW	Kilowatt
4	A	Ampere (unit of current)
5	V	Volts (unit of voltage)
6	Hz	Hertz (unit of frequency)
7	RFID	Radio Frequency Identification

SAFETY INSTRUCTIONS

In this manual, the following warning labels and precautions are used on AC EV Chargers:



WARNING

For use with Electric Vehicles. Ventilation Not Required. To avoid a risk of fire or electric shock, do not use this device with an extension cord. This device is intended only for charging vehicles not requiring ventilation during charging. THE SUITABILITY OF THE USE OF FLEXIBLE CORD IN ACCORDANCE WITH CE CODE, PART I, RULE 4-012, IS TO BE DETERMINED BY THE LOCAL INSPECTION AUTHORITY HAVING JURISDICTION.

CAUTION

To reduce the risk of electric shock, connect only to properly grounded outlets. Do not use this product if there is any damage to the unit. Risk of electric shock, Do not remove cover or attempt to open the enclosure. No user serviceable parts inside. Refer servicing to qualified service personnel.

STANDARD

Safety Standard

UL 2594 UL 2231 UL 1998 UL991

Radio Frequency Standards

47CFR Part 15 (2020)

ANSI C63.4 (2014)

ICES-003 Issue 7: October 2020

Energy Star Standard

ENERGY STAR® Program Requirements for Electric Vehicle Supply Equipment (EVSE)
Version 1.0 and 1.1

Charging Connection

The charging connection method is shown in the figure below

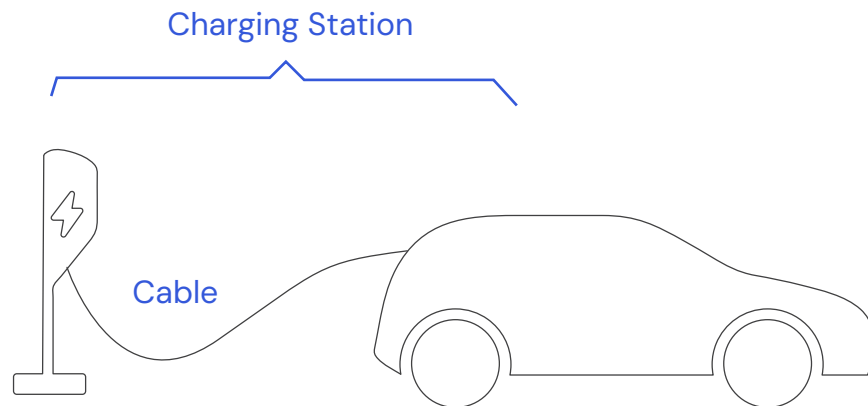

1 PRODUCT INFORMATION

1.1 Type

Welcome to our AC EVSE

1.1.1 Shape and Size

The shape and size of the AC EVSE is shown in the figure below:

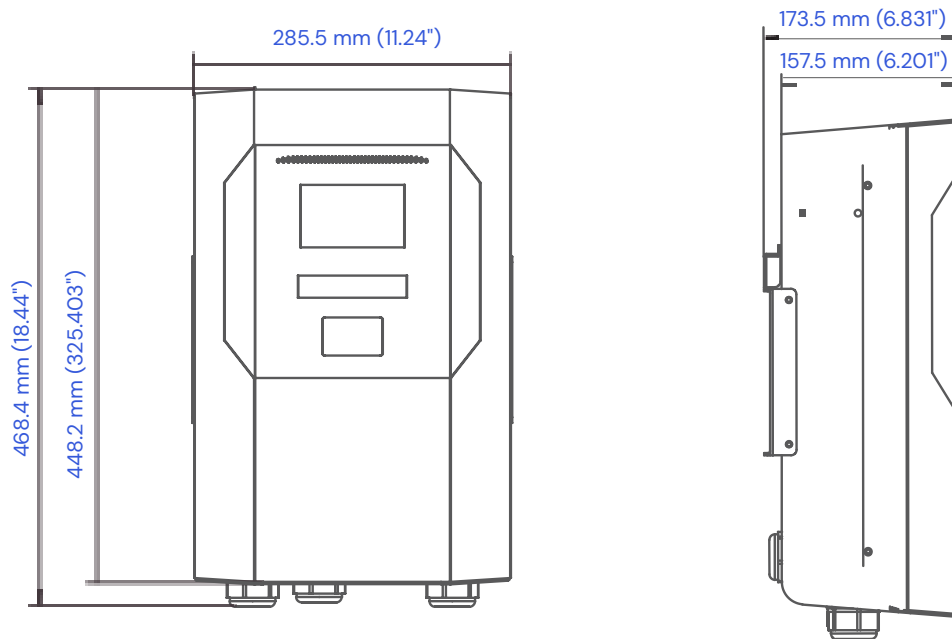

1.1.2 Block Diagram

The block diagram of EVSE is as follows

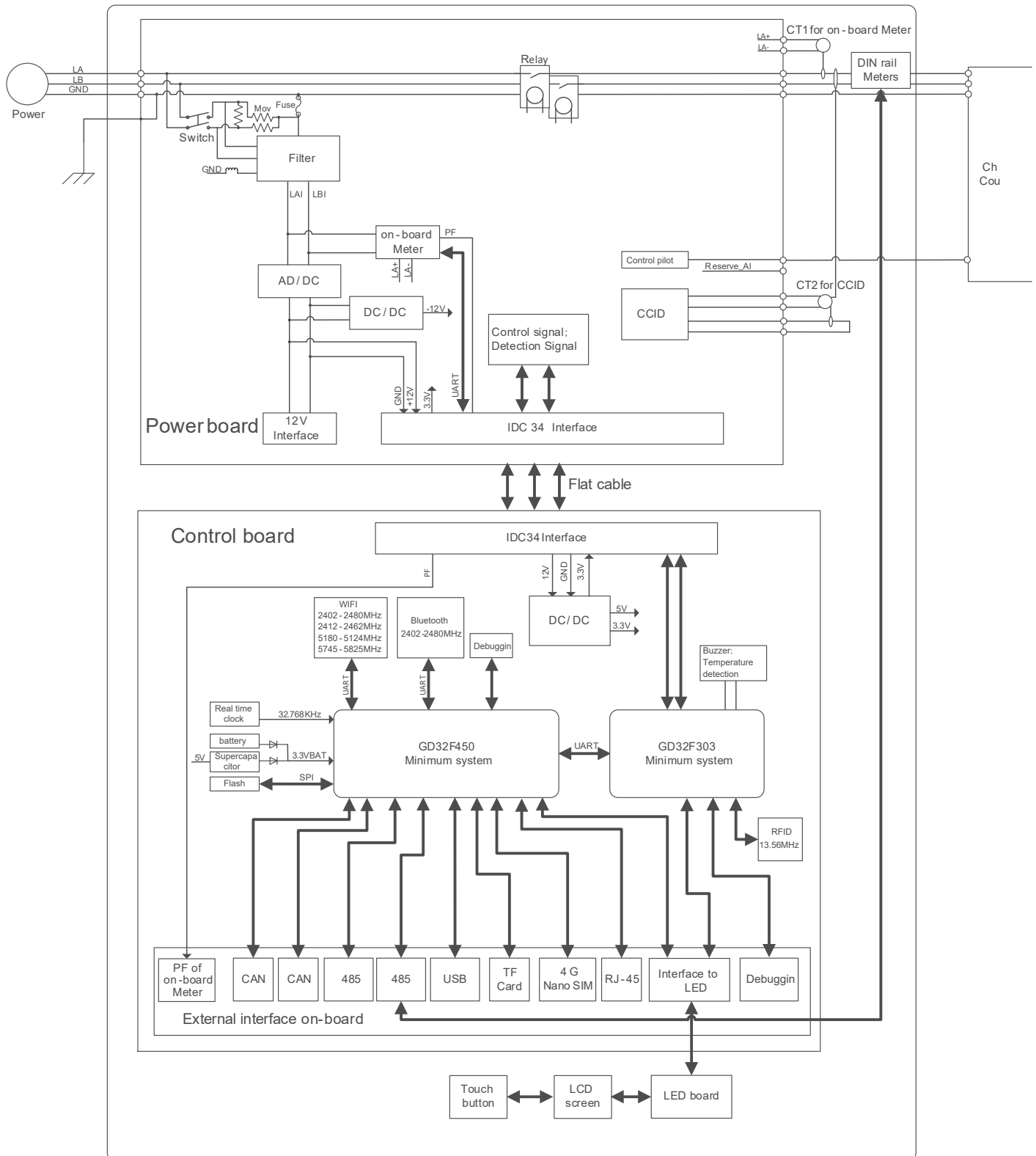

1.1.3. Model definition

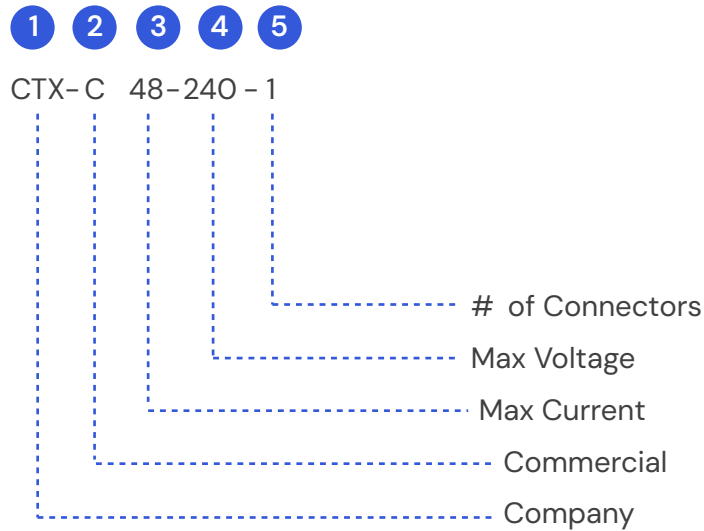

Description of Model Number

1. Represents the company, ChargeTronix

CTX

2. Represents charger type

Power Output Type	Commercial	Residential	Fleet
Code	C	R	F

3. Represents product power output specifications.

Power output	AC mode are marked by maximum output current		
	32A	40A	48A
Code	32	40	48

4. Represents max voltage

Power Input Method	Single Phase 208 or 240 VAC 60Hz
Code	240

5. Represents the number of connectors

# of Connectors	Single Port	Dual Port
Code	1	2

1.2 Empty Seat

- AC EVSE is equipped with an American standard car-side charging connector.
- When the EVSE is in standby mode, insert the car end charging connector into an empty seat to protect the car end charging connector.
- Use the mounting screws to fix this empty socket in place next to the EVSE.

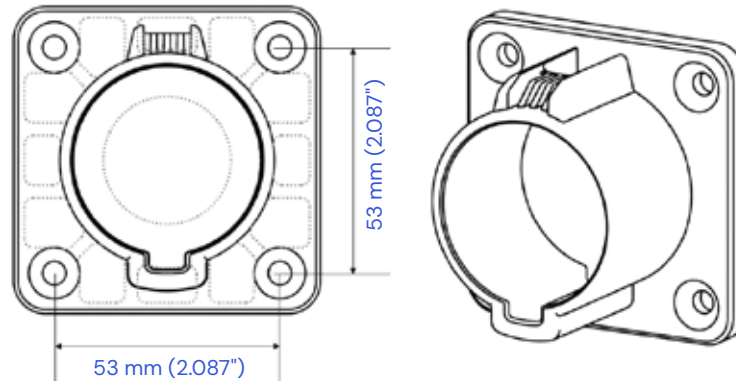

1.3 Specification

RD10 American Standard AC EV Charging Specifications								
Category	Specifications & Parameters							Option
	Model Number	Part Number	Rated Input/ Output (v)	Rated Input (A)	Rated Output (A)	Max Power	Charge Coupler	
Power Specification	CTX-CAC48	CTX-C32-240-1	Level 2, 208/240VAC 60Hz	32A	32A	7.68kW	SAEJ1772 TYPE1/32A	Optional
		CTX-C40-240-1	Level 2, 208/240VAC 60Hz	40A	40A	9.6kW	SAE J1772 TYPE1/40A	Optional
		CTX-C48-240-1	Level 2, 208/240VAC 60Hz	48A	48A	11.52kW	SAEJ1772 TYPE1 /48A	Optional
Power Wiring +B8:H30	Hardwired via pigtail : L1/L2/GND							
Communication	4G cat. 4							
	WiFi 2.4G							Optional
	BLE 5.0							Optional
	RFID							Optional
	LAN (RJ-45)							
	USB (type A)							
	RS-485							Optional
	CAN							Optional
Ocpp Version	Ocpp 1.6J							
User Interface & Control	LCD Screen Size:4.3-inch /pixels resolution:800*480 262K colors No touch function							
	Capacitive touch buttons							Optional
	Power option switch							
User Authentication	Swipe card							
	QR Code /APP							
	ISO 15118 (Plug & Play)							Optional
Meter	Guideway power Meter Build-in							Optional
	On-board power meter							
Power Management	Load Balancing: Operating Stations							

Memory	Flash rom (32M bit)		
	TF card memory expansion (No TF card)		
RealTime clock	Coin Cell Battery		Optional
	Supercapacitor		
Protection Function	CCID20		
	Over Voltage Protection		
	Under Voltage Protection		
	Over-current protection		
	Over Load Protection		
	Short Circuit Protection		
	Ground Protection		
	Over-temp Protection		
	Surge Protection 6 kV @ 3,000A.		
	Fault self-test, Ground Protection		
Environmental	Enclosure Protection	Type 4, IK10	
	Operating Temperature	-30 ~ 50°C	
	Storage Temperature	-40 ~ 75°C	
	Humidity	Up to 95%, non-condensing	
	Altitude	≤2000m	
	Cooling Method	Natural Cooling	
Mechanical	Net Weight	14-16 lbs(32A)/ 19-20 lbs(40A)/ 22-23 lbs(48A)	
	EV Charger	D145mm(5.71") * W245mm(9.65") * H415mm(16.34")	
	Cable Length	18 Ft or Customization	
Regulation	Safety Regulations	14-16 lbs(32A)/ 19-20 lbs(40A)/ 22-23 lbs(48A)	
	Metering & Billing	D145mm(5.71") * W245mm(9.65") * H415mm(16.34")	
	Energy Efficiency	18 Ft or Customization	
	Wireless Certificate	FCC,IC	
Warranty	2 years		

2 OPERATE

2.1 Switch

1. Check and make sure the mainboard power switch is off and that the fuse is there and installed. As shown below.

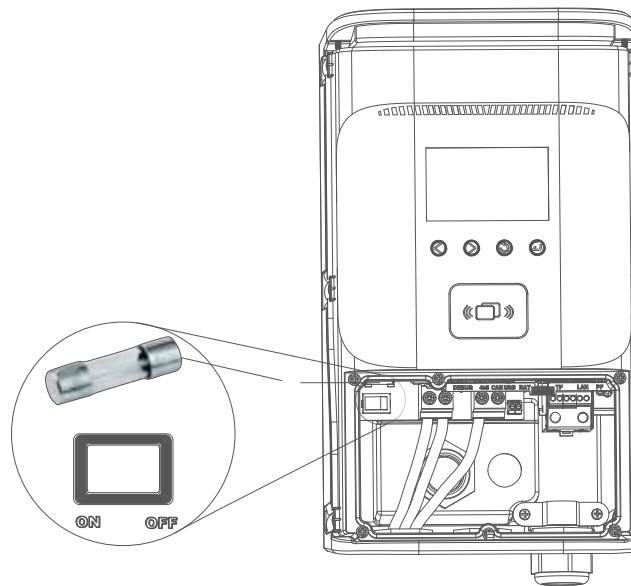

2.2 About the interface

2. Turn off the power of this product, turn on the power switch of the mainboard; observe whether the boot interface of the product is normal.

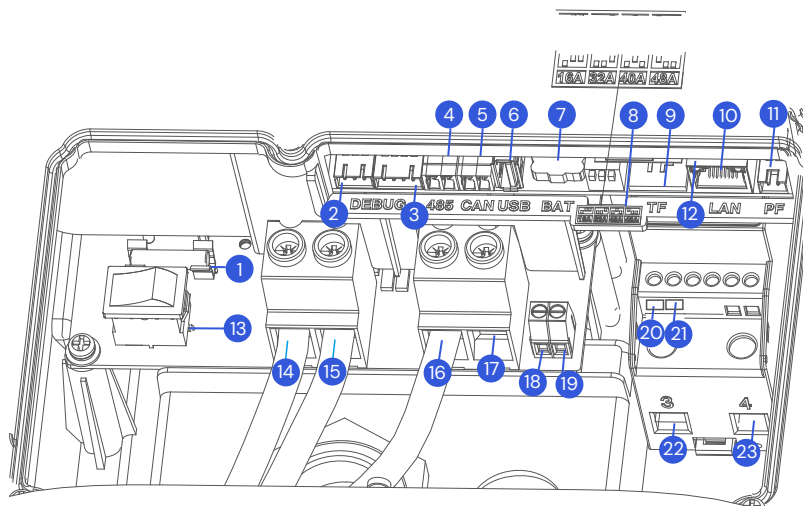

No.	Name	Functions	Specification
1	Fuse	Safety Protection	5*20, 250VAC, 10A
2	Debug serial port	Not open	
3	Download interface	Not open	
4	485 interface	Undeveloped	
5	CAN interface	Undeveloped	
6	USB interface	Undeveloped	
7	Coin cell battery	Clock power supply storage	CR1220
8	Dip switch Control	See picture 1 for setting method, rated current setting	See picture 1 for setting method, rated current setting
9	TF card holder	Undeveloped	Micro SD
10	Ethernet interface (RJ45)	Internet connection	100Mbps
11	PF pulse interface	Meter calibration	Optocoupler output, external pull-up resistor
12	SIM card interface	Internet connection	4G Nano SIM
13	Power switch	Power control	
14	Input L1	Power input	AC 208/240V 50, /60Hz
15	Input L2	Power input	AC 208/240V 50, /60Hz
16	Input GND	Power input	
17	Cable GND	Power output	
18	Reserved interface		
19	CP interface	Charging control guide	
20	RS485 interface A	Meter communication	
21	RS485 interface B	Meter communication	
22	Cable L2	Power output	Depending on input
23	Cable L1	Power output	Depending on input

3 FEATURES

3.1 User Interface & Control

3.1.1 User Interface & Control

Take the ready state screen as an example to illustrate the meanings of common elements in the user interface interaction interface.



1. The electrical parameters are displayed in the upper left corner of the status bar, and the order from left to right is: charging power, voltage level, and rated current.





The charging power is calculated by multiplying the grid voltage and the rated current. The voltage level is automatically detected as "208VAC" or "240VAC" when powering on. Rated current can be set by dial switch. For details on dial settings, please refer to the interface introduction and instructions.



2. The upper right corner of the status bar displays network communication parameters. From left to right, there are Bluetooth, 4G, WIFI, Ethernet and Fahrenheit icons in the charger. The Bluetooth icon only appears when a Bluetooth module is installed. If the 4G module is not installed, it is a gray low-light icon, and if the 4G module is installed normally, it is a white high-light icon. WIFI is a gray low-light icon if not connected, and a white high-light icon when WIFI is properly set up and successfully connected. Ethernet is a gray low-light icon if communication with the router is not established, and white high-light icon when successfully established. The temperature inside the stake has a white highlighted icon, it's dynamic, and it's displayed in degrees Fahrenheit.





3. Status prompts vary as per different language and different status.

4. Language switching prompt is unique to the "Ready" screen. When you touch the button below, you can switch between English and French. Currently, these are the only two languages available.

5. The main interface displays different content under each status.
6. Charging pile SN code –the unique code assigned at the time of delivery. The client can modify it through the server, but the uniqueness of the modification cannot be guaranteed.
7. After-sales service telephone.
8. U stands for UI and display project file version, H stands for firmware version .

Status	Display Description	LED Description	Current Status Interactive Functions
Power On		No operation is recommended at this stage	No operation is recommended
Available		Green Always On	<ol style="list-style-type: none"> 1. Enter to the available page after the boot up finished; 2. Touch the button to switch language; 3. If there is no operation, the screen will dim automatically in 3 minutes; 4. Screen can be wake up through either of following ways: touch button, insert the coupler, scan the code, tap the card, or other platform inter-action
Start Charge (Insert the coupler and tap the card or app scan		The green light is flashing fast.	<ol style="list-style-type: none"> 1. Start charging through RFID card, QR code scanning or APP, If charging coupler not plugged, it will notify for charging coupler plugging as shown left; 2. The interface will stay for 1 minute, if the user does not insert the plug within 1 minute, it will return to the standby mode, the waiting time can be modified in the remote server.
			<ol style="list-style-type: none"> 1. The user plugs in the coupler and jumps from standby to a page that prompts the user to initiate charging; 2. This state will wait for the user to initiate charging; 3. The user removes the charging coupler and returns to the standby page.
Charging coupler plugged , but car not ready		Blue light slow flash	<ol style="list-style-type: none"> 1. After inserting the coupler and starting charging, the S2 switch inside the car is not closed, and it is not ready for charging, will jumps to the car not ready page; 2. Enter the charging page when the car is ready; 3. If you unplug the charging cable at this time, the battery will return to the standby page.
Charging		Blue is always on	<ol style="list-style-type: none"> 1. Enter the charging page after successfully starting charging; 2. Actively end charging in this state (tap card, APP, platform remote control), will jump to the settlement interface; 3. In this state, the tip of the coupler is loose, (pull out the plug), will jump to the abnormal settlement interface.

Status	Display Description	LED Description	Current Status Interactive Functions
Complete		Purple is always on	<ol style="list-style-type: none"> 1. After the charging is completed normally, enter the charging completion settlement page; 2. Unplug the plug and return to the standby screen.
Fault		Unrecoverable fault: red is always on Recoverable fault – slow flashing red	<ol style="list-style-type: none"> 1. If an abnormality occurs in the non-charging state, jump to the fault prompt page; 2. Recoverable faults: undervoltage, overvoltage, overtemperature, leakage, short circuit, overcurrent, ground fault; 3. Non-recoverable faults: CP voltage abnormality, instrument failure, relay adhesion; 4. If the fault is resolved, return to the interface before the fault was reported.
Settlement Fault		Unrecoverable fault: steady red Recoverable fault – slow flashing red	<ol style="list-style-type: none"> 1. If an abnormality occurs during charging, enter the fault settlement page; 2. Recoverable faults: undervoltage, overvoltage, overtemperature, leakage, short circuit, overcurrent, ground fault, etc; 3. Non-recoverable faults: CP voltage abnormality, instrument failure, relay adhesion, abnormality of functional modules, etc; 4. Unplug the plug in this state, if the fault is not resolved, it will enter the fault prompt page; if the fault is resolved, it will return to the standby page.
Abnormal settlement		Purple slow flash	<ol style="list-style-type: none"> 1. The plug is loose in the charging state, or is pulled out by external force to enter the settlement page of the connection and disconnection of the coupler head; 2. Hold for 1 minute and return to the standby page; 3. Re-plug the plug, you need to restart the charging process.
Reserved		Green slow flash	<ol style="list-style-type: none"> 1. The user selects the electric pile in the APP, and enters the reserved page after operating the scheduled charging; 2. Only reserved users can start charging; 3. When non-re-served users start charging, it will prompt that the electric pile has been reserved; 4. After the scheduled time is exceeded, if the customer is not present for use, it will automatically return to the standby page.

Status	Display Description	LED Description	Current Status Interactive Functions
System update		Yellow slow flash	<ol style="list-style-type: none"> 1. Perform remote OTA in standby state, in this state, there will be a percentage figure to show upgrading process. Download the firmware until complete, then it will confirm and check the content of the upgrade package; 2. When the download is complete and the verification is successful, it will enter the upgrade success state; 3. During the download process, if the network is disconnected or the verification fails after the download is complete, it will enter to upgrade failure state; 4. After the upgrade is complete, the firmware version number in the bottom right corner will be updated.
System Update Succeeded		Yellow slow flash	<ol style="list-style-type: none"> 1. After the firmware OTA update is successful, jump to the upgrade success page; 2. After waiting for 10 seconds, turn on the power pile and restart.
System Update Failed		Yellow slow flash	<ol style="list-style-type: none"> 1. If the upgrade fails, enter the upgrade failure prompt page; 2. Wait for 10 seconds and return to the state before the firmware upgrade.
System Update Failed		Steady yellow	<ol style="list-style-type: none"> 1. In the standby state, will enter to out of service state when receive "stop use" command from the server; 2. Return to the standby state when receive "recover to use" command from server.

3.2 Switch

Internet configuration via WiFi and OCPP Authpass

Take the laptop configuration charger parameters as an example, the introduction is as follows. (The method of setting parameters with a mobile phone is similar and will not be repeated).

Step 1: Connect to WiFi Hotspot.

Keep your laptop in a state where it can connect to a Wi-Fi hotspot. Turn on the charger, find the hotspot named "CHARGE TRONIX", and connect to it without a password. (If you do not find a hotspot named "CHARGE TRONIX", please restart the power of the charging station).

Step 2: Log in to Settings.

Open a web browser, preferably Google Chrome or Microsoft Edge, and fill in the – IP address "192.168.4.1" in the browser's address bar. Press the Enter key to enter the page of EVSE CONFIGURATION LOGIN. (Note: Microsoft IE browser cannot visit).

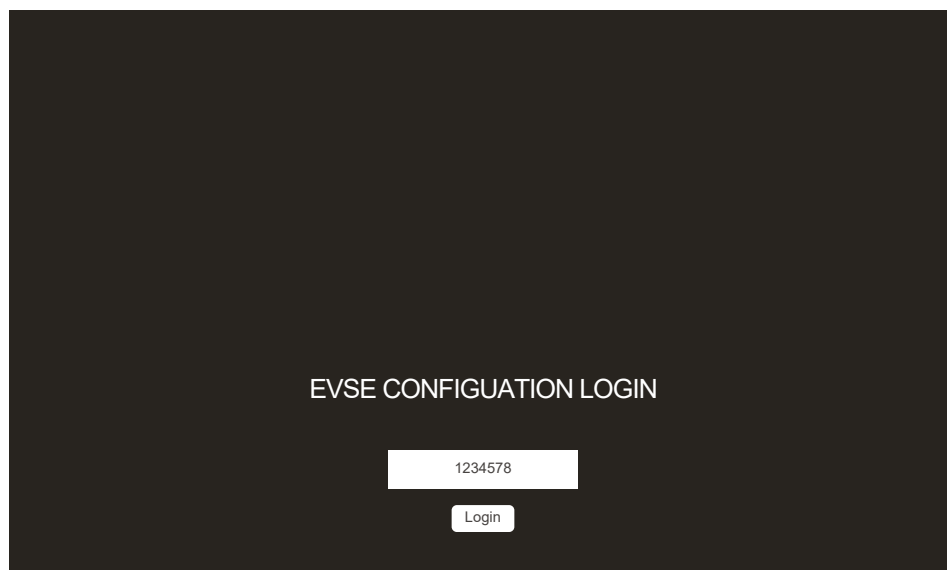

Step 3: Configure Your EV Charger.

Fill in the default password "12345678" to enter this page. When you log in to this page for the first time, please change to a new login password.

EVSE CONFIGURATION

Advanced Options	
Serial Number:	<input type="text" value="3885233376195"/>
OCPP Version:	<input type="text" value="OCPP1.6-J"/>
OCPP Server:	<input type="text" value="wss://centralsystem.ampup.io/ocpp/longt"/>
OCPP AuthPass:	<input type="text" value="0"/>
Connect Alternative Server:	<input type="text" value="YES"/>
New password:	<input type="text" value="Enter a new password of 1 to 9 characters"/>
	<input type="text" value="Enter password again"/>
Network Setting	
DHCP	<input type="text" value="On"/>
Static IP:	<input type="text" value="192.168.8.100"/>
Static Gateway:	<input type="text" value="192.168.8.1"/>
Static Mask:	<input type="text" value="255.255.255.0"/>
4G APN:	<input type="text"/>
4G USER:	<input type="text"/>
4G Password:	<input type="text"/>

User Options	
WiFi SSID:	<input type="text" value="-"/>
WiFi Password:	<input type="text" value="12345678"/>
Plug and Play:	<input type="text" value="Disable"/>
Share Current:	<input type="text" value="0"/>
Modbus Address:	<input type="text" value="0"/>
Advanced Options	
Serial Number:	<input type="text" value="3885233376195"/>
OCPP Version:	<input type="text" value="OCPP1.6-J"/>
OCPP Server:	<input type="text" value="wss://centralsystem.ampup.io/ocpp/CHAR"/>
OCPP AuthPass:	<input type="text" value="0"/>
Connect Alternative Server:	<input type="text" value="YES"/>
New password:	<input type="text" value="Enter a new password of 1 to 9 characters"/>
	<input type="text" value="Enter password again"/>
Network Setting	
DHCP	<input type="text" value="On"/>
Static IP:	<input type="text" value="192.168.8.100"/>
Static Gateway:	<input type="text" value="192.168.8.1"/>
Static Mask:	<input type="text" value="255.255.255.0"/>

Fill in the name of the hotspot and the password of your WiFi router on the web page, click the "SAVE" button to save the settings, and click the "RESTART" button to restart the charging pile to make the settings take effect. Once it takes effect, the charging pile can be accessed through your WiFi router the Internet.

3.2 Operation Guide

1. Charging Preparation:

A. Find the charging pile product in the idle standby state, park the car, turn off the vehicle, and make the electric car in a chargeable state.



B. If choose to use APP: You can download the APP according to the prompts, and register an account according to the prompts.



C. If choose to use an RFID card: Contact the operator to obtain an RFID card; the private pile is equipped with an RFID card in the box.

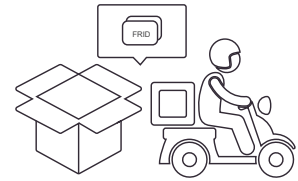

2. To Connect The Charging Connector

Open the cover of the car charging socket, and connect the charging cable to the car socket stably. Make sure the connection is successful.

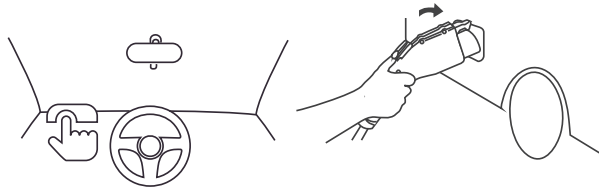

3. Start Charging



A. Plug and charge

The charging mode is configured as plug and charge, when step 2 is completed, the car is ready to start charging.



B. Tap card to start

Put the RFID card close to the card-tapping area to start charging by tapping the card, and tap the card again during the charging process to end the charging.

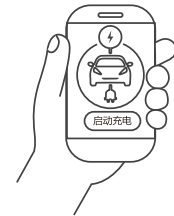

C. APP start and stop

Use the APP to scan the QR code to start charging, or connect to the electric pile through the Bluetooth of the mobile phone to start charging.

4. Charging:

During the charging process, the charging pile screen will display the charging voltage, charging current, charging time,

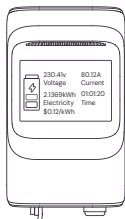

5. End Charging:

A. Through charging, the car owner can take initiative to end the charging through tap RFID card or stop on APP or can be stopped through the car terminal for plug-and-play charging situation.



B. After the car is fully charged, it can automatically end the charging.

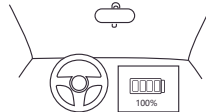

C. After the charging is completed, please pull out the charging coupler and put it back to the empty couplerholder and hang the cables back on the hook.

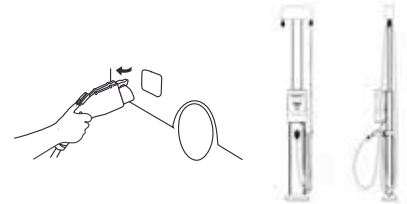

6. Order Settlement:

After the charging is completed, the display screen will display the charging power and charging cost. The order settlement will be completed on the APP or platform. Private piles and non-charging electric piles will display the charging power.

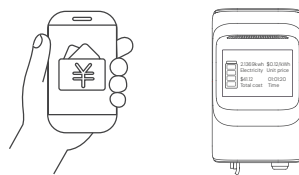

7. Abnormal Situation:

In any state, if there is abnormal prompt on the screen and the light bar, please stop charging and disconnect the charging cable from the socket on the car.

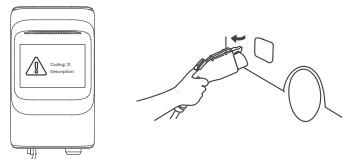

3.4 Troubleshooting

When a fault occurs, the charger will automatically protect. The fault information and processing methods are as follows.

Fault Code	Handling Method
Code 11: CP failure	Check that the adapter is properly connected to the electric vehicle, pull and plug the adapter and try charging again.
Code 13: Under voltage fault	Check that the input cable is reliably connected, that the parent grid is properly connected, and that the grid voltage is abnormal.
Code 14: Over voltage fault	Check whether the input cable is connected correctly; Whether the grid voltage is abnormal.
Code 15: Over temperature fault	Check whether the charging station is covered or installed in a high temperature environment.
Code 16: Meter failure	It is recommended to reboot on the power, there is a fault if you need to return to the factory.
Code 17: Leakage fault	Check whether the charging adapter and its cable are damaged or wet. Recover after pulling out the adapter.
Code 18: Short circuit fault	Check whether the charging adapter and its cables are damaged or wet.
Code 19: Over current fault	Check whether the charging adapter is correctly connected to the car, and check whether the on-board charger is normal.
Code 23: Relay sticking fault	The equipment is damaged and needs to be returned to the factory for repair.
Code 24: Leakagecurrent device failure	Users need to re-plug the coupler or contact the after-sales service.
Code 25: Ground fault	The charging pile is not grounded, so the circuit needs to be tested.

4 INSTALL

4.1 Label

On the EVSE shell, there is a nameplate identifying the charger model and specifications, the content of which is as follows.



4.2 Package

4.2.1 Packing List

- | | | | | |
|------------------------|---------------------------|--|--|--|
| | <p>1</p> | <p>2</p> | <p>3</p> | <p>4</p> |
| AC charger | RFID card (2pcs) | Coupler holder (1pcs) | Cord holder (1pcs) | Torx self-tapping screws (8pcs)
Rubber Plug Expansion Tube (8pcs) |
| <p>5</p> | <p>6</p> | <p>7</p> | <p>8</p> | <p>9</p> |
| Expansion screw (3pcs) | Electric drill bit (1pcs) | 3-hole waterproof connector BN-M32-25 (1pcs) | 3-hole waterproof connector BN-M25-18 (1pcs) | VE tube terminal (3pcs) |

4.2.2 Check and Confirm

When unpacking, please confirm the following points carefully:

- According to the packing list, whether the accessories are complete.
- Whether there is any damage during transportation.
- Whether the model and specification on the nameplate of the machine are consistent with the order requirements.
- If any damaged or missing parts are found, please do not start the machine and contact the supplier as soon as possible.
- Please keep the box and packaging materials for 1 month for future disposal. Paper packaging is recyclable.

4.3 Preparation

In order to ensure the long-term stable operation of the product, it is recommended to avoid the following installation problems.

- This product is an electrical device. Handle with care and avoid severe vibration and shock.
- EVSE cannot be transported by dragging the charging connector and charging cable.
- EVSE cannot be used in extreme weather, especially when the ambient temperature is too low or too high, which will affect the use of EVSE.

It is recommended to install EVSE in a ventilated and cool place away from direct sunlight and rain. To ensure good ventilation, you should install the EVSE vertically with enough space. Installation tools
Before installing AC EVSE, you should at least prepare the following tools.



Multimeter

Electric impact drill
(D8mm+D6mm)

Wrench (10mm)



Wire strippers

AWG23-7
Tube terminal
crimping pliersPhillips screwdriver
(D5mm)Electric batch
(with plum blossom
hole T20.T25 bit)

Marker pen



Utility knife



Anti-static bracelet



Heat coupler



Rubber hammer

4.4 Installation Steps

4.4.1 Mount the EVSE on the Wall as Follows

Location Requirements



Angle Requirements

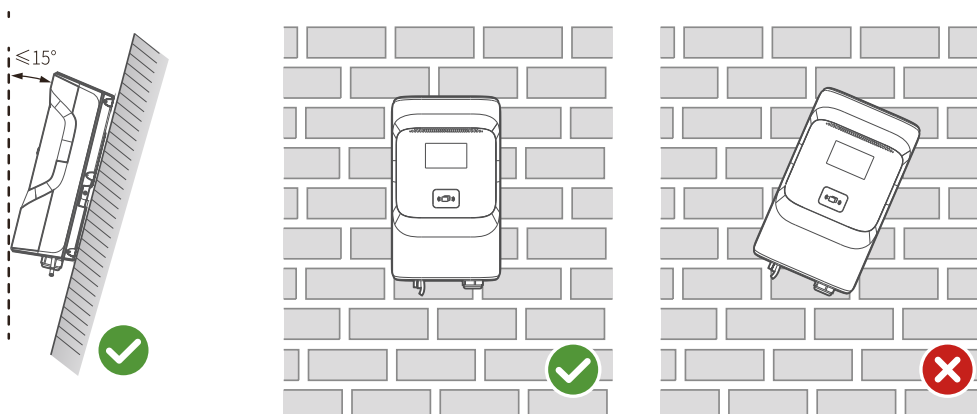

Wall-mounted Installation Steps

- 1 Install the wall-mounted version and trace holes on the wall.

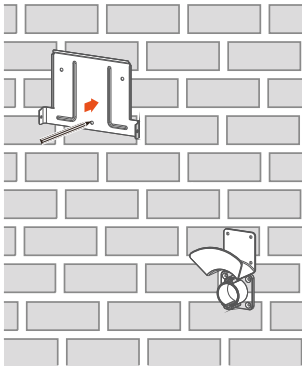

- 2 Punch holes in the wall.

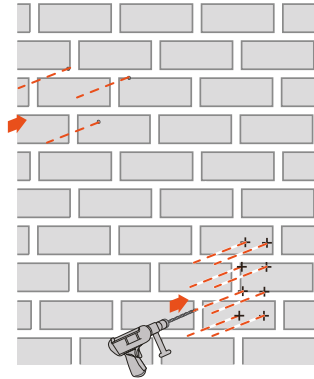

- 3 Install Wall Mounts, Hanging Plates and Empty Blocks.

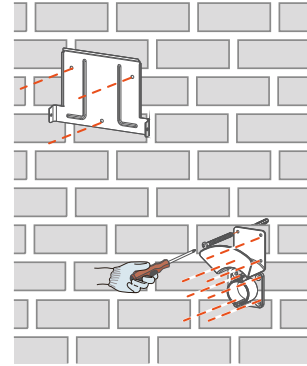

- 4 Install piles on the wall.

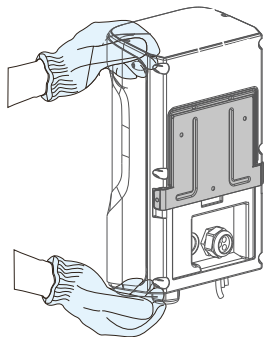

- 5 Set screw.

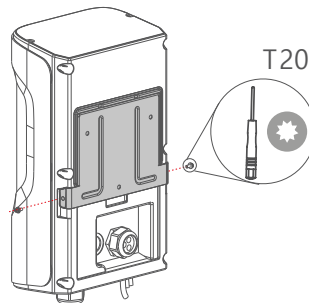

- 6 Schematic diagram of the completion of the installation pile.

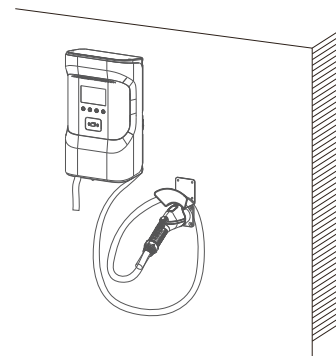

Product Wiring

- 1 Remove the decorative shell.

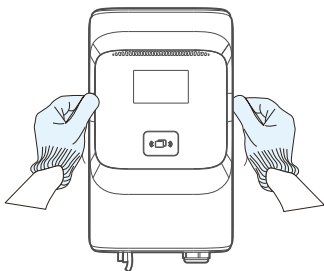

- 2 Remove the wiring cover.

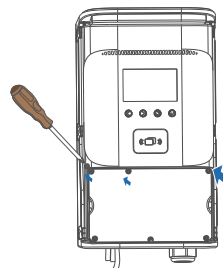

- 3 Wiring.

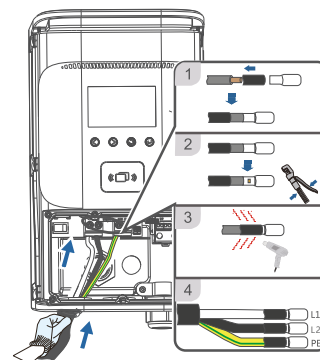

4 Lock wire cover.

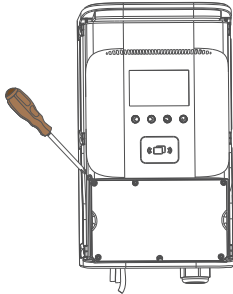

5 Reinstall the trim case.

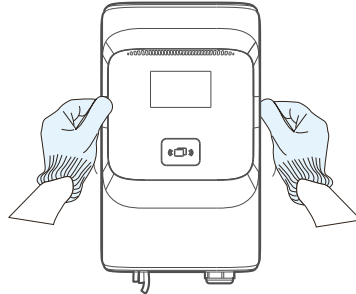

6 Tighten the screws of the decorative cover.

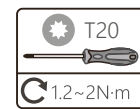
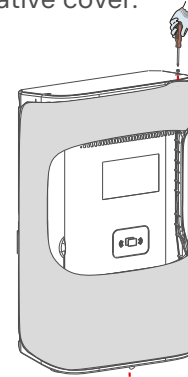

4.4.2 Column installation

Schematic Diagram of Column Decomposition

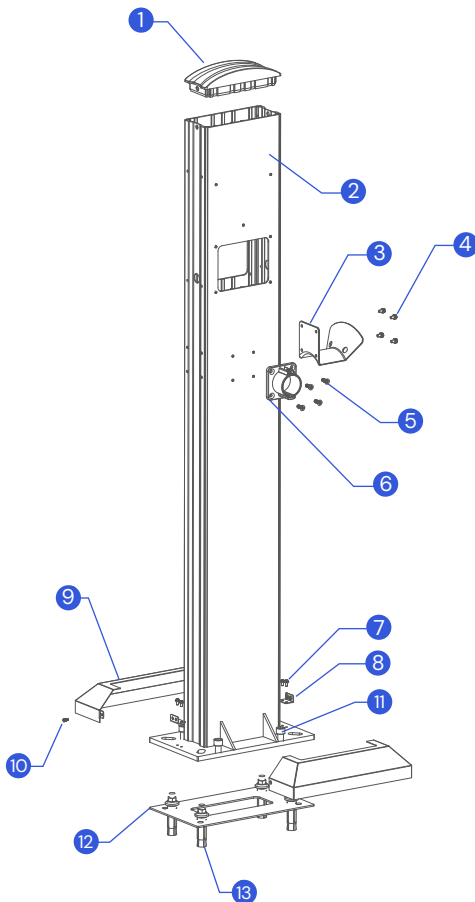

Number	Name	Material	Quantity
1	Column cap	Silica gel	1
2	Column Boom	AL6063-T6+Oxidation 1	1
3	Hook up	SGCC+baking paint	1
4	M5*12 combination screw	Stainless steel	4
5	M5*20 countersunk head screw	Stainless steel	4
6	Coupler mount	Nylon	1
7	M4*10 combination screw	Stainless steel	4
8	Floor bracket	SGCC+baking paint	2
9	Base cover	SGCC+baking paint	2
10	M4*10 countersunk head screw	Stainless steel	2
11	M12*30 hexagon socket screw	Stainless steel	4
12	Leveling pad	Stainless steel	1
13	M12*120 expansion screw	Stainless steel	4

Schematic diagram of column installation

Cement foundation size chart.

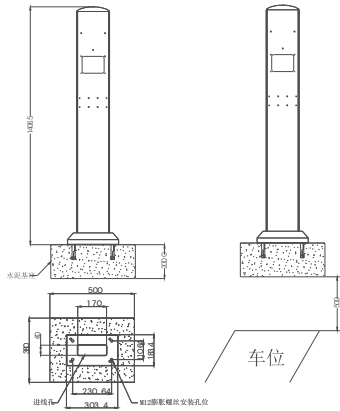

1 Pull wire.

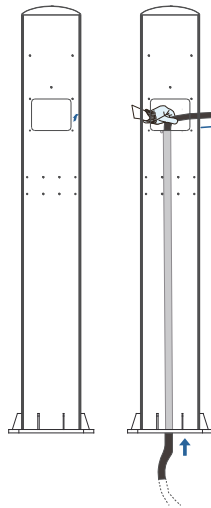

2 Fixed column.

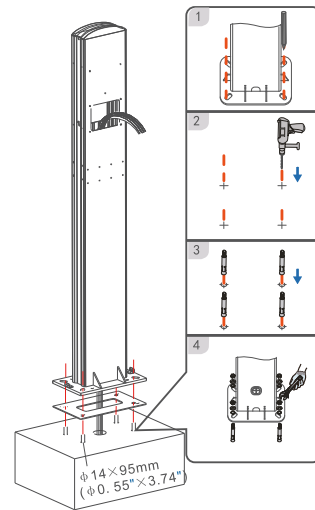

3 Fixed base cover.

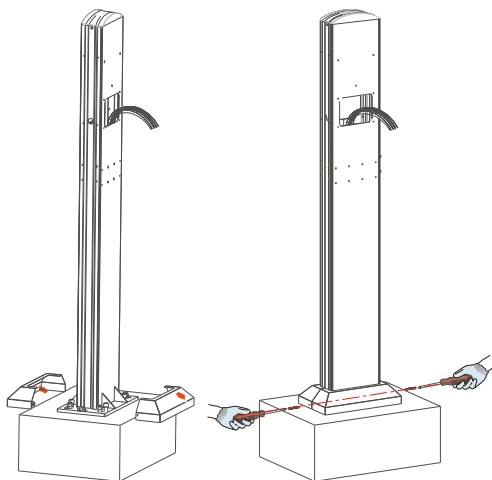

4 Install empty seat.

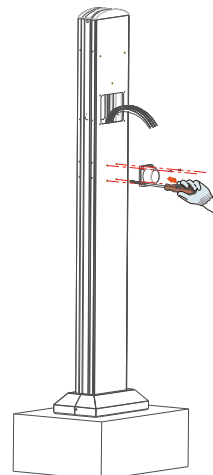

5 Install the hanging board.

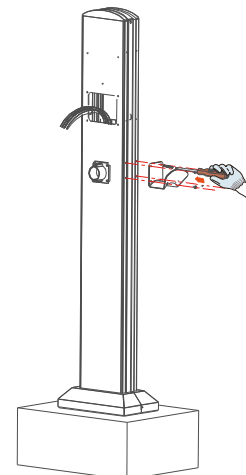

6 Install wall panel.

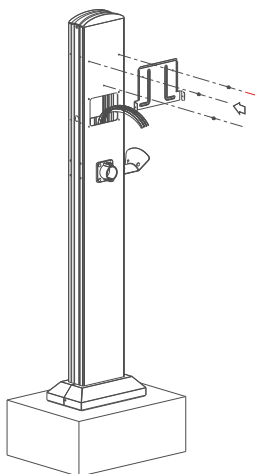

7 Install the pile.

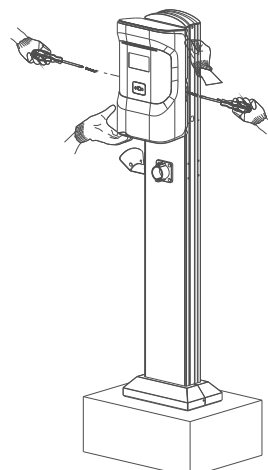

8 The input surface mounting holes are changed to surface mounting holes, and the wiring on the back.

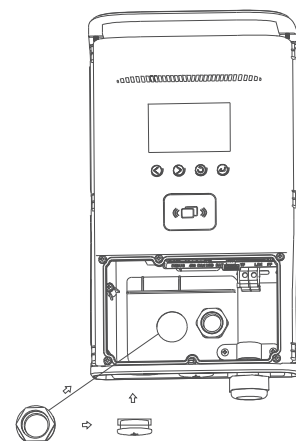

9 Input line terminal crimping tube type terminal.

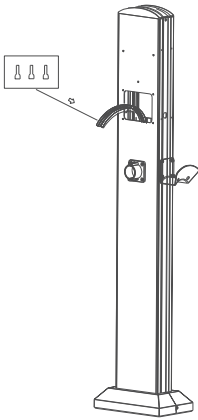

10 Concealed hole installation three-hole waterproof connector.

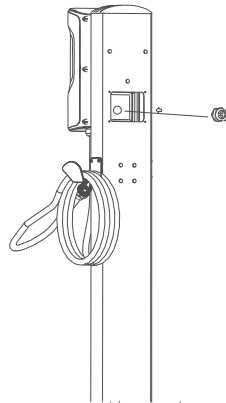

11 The input line passes through the three-hole waterproof connector.

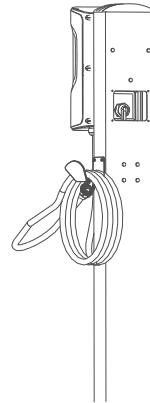

12 Lock the seal.

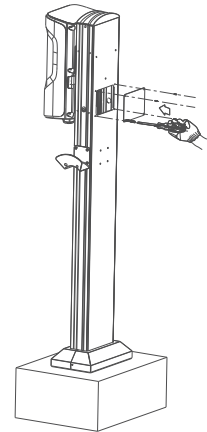

Product wiring

1 Remove the decorative shell.

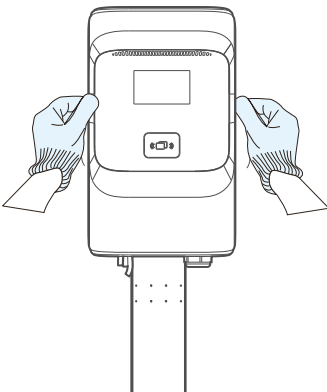

2 Remove the wiring cover.

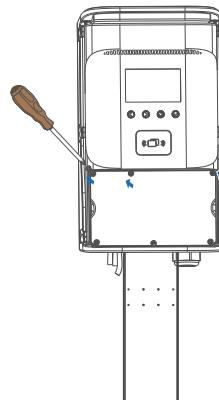

3 Wiring.

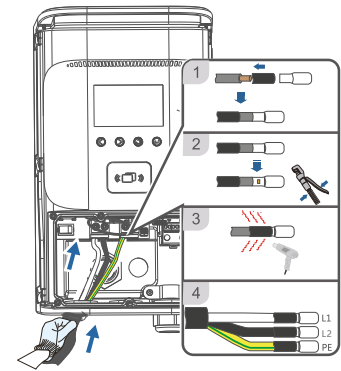

4 Lock wire cover.

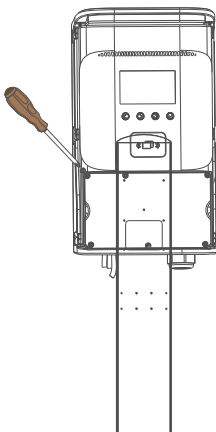

5 Reinstall the trim case.

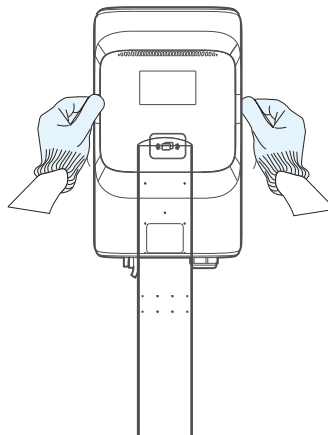

6 Tighten the screws for the decorative cover.

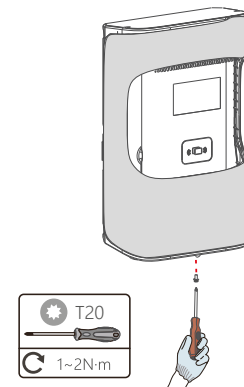

After installation

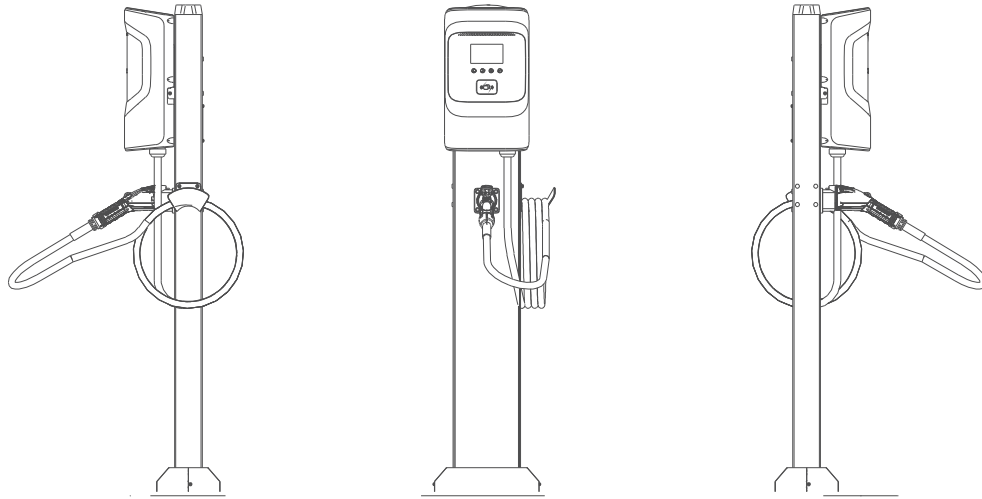

4.5 Grounding Instructions

This product must be connected to a grounded, metallic, permanent wiring system, or an equipment ground wire must be run with the circuit conductor and connected to the equipment ground terminal or conductor on the product.

The ground conductor must run with the circuit conductors and be connected to the equipment ground terminal or conductor on the product.

Wiring port	L1I	L2I	PE	CP
Crimp Terminal Specifications	E10-18	E6018	E1508	E10-12
Installation Tool Specifications	Diameter 3mm (0.1181") flat-blade screwdriver Diameter 5mm (0.1968") flat-blade screwdriver Diameter 5mm–6mm Phillips screwdriver			
Wiring tightening torque	2~5N m			

4.6 Maintain

To ensure the long-term stable operation of the device, please perform regular (usually monthly) maintenance on the device according to the operating environment.

- (a) Equipment is maintained by professionals.
- (b) Check if the equipment is well grounded and safe.
- (c) Check whether there are potential safety hazards around the charging pile, such as whether there are high-temperature, corrosive, or flammable and explosive items near the charger.
- (d) Check whether the connection points of the input terminals are in good contact and whether there is any abnormality. Check other wiring points for looseness.

WARRANTY

1. The scope of the warranty refers to the product itself.
2. The warranty period is 24 months. During the warranty period, if the product fails or is damaged under normal use (determined by the company's technicians), the company will repair it free of charge.
3. The starting time of the warranty period is the production date of the product.
4. Even within the warranty period, if the following conditions occur, a certain maintenance fee will be charged.
 - Equipment failure caused for not operate according to the user manual.
 - Equipment damage caused by fire, flood, abnormal voltage, etc.
 - Equipment damage caused by abnormal function of the product.
 - Equipment damage caused by the entry of foreign objects.
 - Equipment damage caused by other human-made external factors.
5. The service fee shall be calculated according to the actual cost. If there is any other contract, this contract shall prevail.
6. During the warranty period, please be sure to keep this card and show it to the maintenance personnel.
7. If you have any questions, please contact the agent or our company directly.



For Both FCC & IC application:

This device complies with Part 15 of the FCC Rules / Industry Canada licence-exempt RSS standard(s). Operation is subject to the following two conditions: (1) this device may not cause harmful interference, and (2) this device must accept any interference received, including interference that may cause undesired operation.

Changes or modifications not expressly approved by the party responsible for compliance could void the user's authority to operate the equipment.

This equipment has been tested and found to comply with the limits for a Class B digital device, pursuant to part 15 of the FCC Rules. These limits are designed to provide reasonable protection against harmful interference in a residential installation. This equipment generates uses and can radiate radio frequency energy and, if not installed and used in accordance with the instructions, may cause harmful interference to radio communications. However, there is no guarantee that interference will not occur in a particular installation. If this equipment does cause harmful interference to radio or television reception, which can be determined by turning the equipment off and on, the user is encouraged to try to correct the interference by one or more of the following measures:

- Reorient or relocate the receiving antenna.
- Increase the separation between the equipment and receiver.
- Connect the equipment into an outlet on a circuit different from that to which the receiver is connected.
- Consult the dealer or an experienced radio/TV technician for help.

MPE Requirements

To satisfy FCC / IC RF exposure requirements, a separation distance of 20 cm or more should be maintained between the antenna of this device and persons during device operation.

To ensure compliance, operations at closer than this distance is not recommended.