

# 48A Flux AC Charger

## User Manual



# Important Safety Instructions Related To Risk Of fire or Electric Shock

**WARNING:** When working with electrical products, basic precautions should always be followed. This manual contains important instructions for CTX-C32-240-1, CTX-C40-240-1, CTX-C48-240-1 models, needs to be observed during installing, operating and maintaining.

1. Please read all instructions before using this product.
2. Use of this device around children should be done under supervision.
3. Do not stick your fingers into the EV connector.
4. Do not use this product if the flexible power cord or scooter cable is frayed, has torn insulation, or has any other damage.
5. Do not use this product if the housing or EV connector is broken, cracked, open, or otherwise damaged.
6. Indicate the ambient temperature grade: -30°C to 50°C.
7. Note the following or something similar: "To reduce the risk of fire, connect to a circuit providing the following function". @ampere's maximum branch circuit overcurrent protection shall be in accordance with the National Electrical Code ANSI/NFPA 70, and Canadian Electrical Code Part 1 C22.1.
8. Disconnecting Means. For equipment rated more than 60 amperes or more than 150 volts to ground, the disconnecting means shall be provided and installed in a readily accessible location. The disconnecting means shall be lockable open in accordance with 110.25.

Model	Required Service Panel Breaker
CTX-C32-240-1	40A
CTX-C40-240-1	50A
CTX-C48-240-1	60A

# CONTENTS

1. Acronym.....	5
2. Safety Instructions.....	5
3. Compliance with Standard.....	6
3.1. Safety Standard.....	6
3.2. Charging Modes and Connections.....	6
4. Product Information.....	7
4.1. Type.....	7
4.1.1. Shape and Size.....	7
4.1.2. Block Diagram.....	8
4.2. Socket.....	9
4.3. Specifications.....	9
5. Operation.....	12
5.1 Switch.....	12
5.2 About the Interface.....	13
6. Features	
6.1 User Interface & Control.....	15
6.2 Configure WiFi Network (Currently no APP).....	20
6.3 Operation Guide.....	22
6.4 Troubleshooting.....	24

7 Installation.....25

    7.1 Labels.....25

    7.2 Packaging.....25

        7.2.1 Packing List.....25

        7.2.2 Check and Confirm.....26

    7.3 Preparation.....26

    7.4 Installation Steps.....27

    7.5 Grounding Instructions.....29

    7.6 Maintenance.....29

Warranty Agreement.....30



# 1. Acronyms

S/N	Abbreviations	Description
1	EV IPHEV	Electric vehicle, which can be a BEV (battery electric vehicle) or a PHEV (plug-in hybrid electric vehicle)
2	EVSE	Electric Vehicle Supply Equipment
3	kW	Kilowatt
4	A	Ampere (unit of current)
5	V	Volts (voltage unit)
6	Hz	Hertz (unit of frequency)
7	RFID	Radio frequency identification

# 2. Safety Instructions

In this manual, the following warning labels and precautions are used in the AC EV Charger:



For use with Electric Vehicles.

Ventilation Not Required.

To avoid a risk of fire or electric shock, do not use this device with an extension cord.

This device is intended only for charging vehicles not requiring ventilation during charging.

THE SUITABILITY OF THE USE OF FLEXIBLE CORD IN ACCORDANCE WITH CE CODE, PART I

## CAUTION

To reduce the risk of electric shock, Connect only to properly grounded outlets.

Do not use this product if there is any damage to the unit.

Risk of electric shock, do not remove cover or attempt to open the enclosure. No user serviceable Parts inside, Refer servicing to qualified service personnel.



## AVERTISSEMENT

Pour utilisation avec des véhicules électriques

Aucune ventilation requise

Pour réduire le risque de choc électrique ou d'incendie, ne pas utiliser de rallonge avec cet appareil

Ce dispositif est destiné au chargement des véhicules ne nécessitant pas de ventilation au cours du chargement

LA PERTINENCE DE L'UTILISATION DE CORDONS FLEXIBLES SELON LE CODE CE, PREMIERE PARTIE.

## ATTENTION

Pour réduire le risque de choc électrique, brancher sur une prise correctement mise à la terre

Ne pas utiliser ce produit si l'appareil est endommagé

Risque de choc électrique. Ne pas retirer le couvercle ni essayer d'ouvrir le boîtier. Aucune pièce interne réparable par l'utilisateur. Confier tout travail d'entretien ou de réparation à un technicien qualifié.



# 3. Standard

## 3.1 Safety Standard

UL 2594 UL 2231 UL 1998 UL991

## 3.2 Radio Frequency Standards

47CFR Part 15 (2020)

ANSI C63.4 (2014)

ICES-003 Issue 7: October 2020

## 3.3 Energy Star Standard

ENERGY STAR® Program Requirements for Electric Vehicle Supply Equipment (EVSE) Version 1.0, 1.1 and 1.2

## 3.4 Charging Connection

The charging connection method is shown in the figure below.

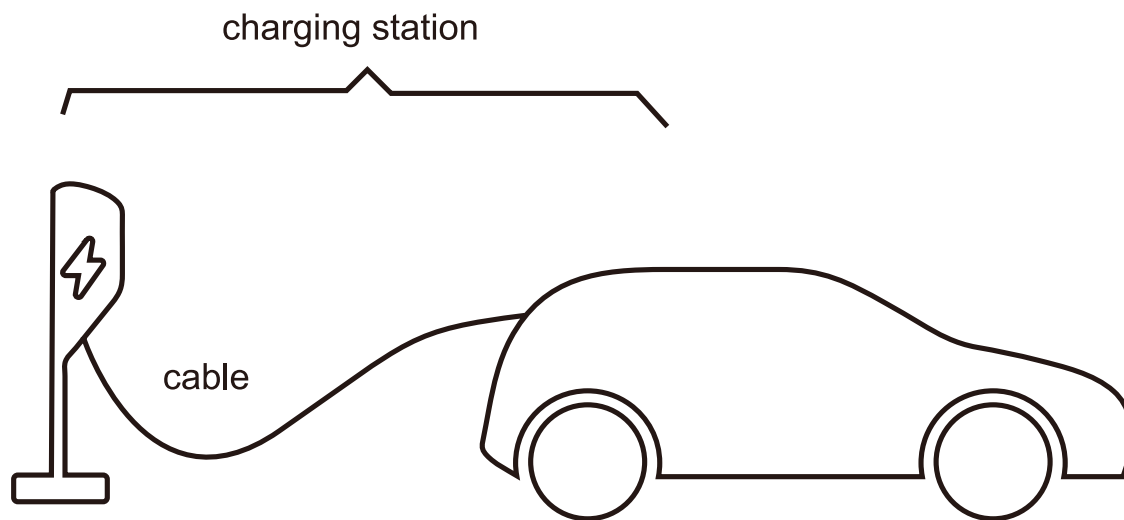

# 4. Product Information

## 4.1 Type

Welcome to our AC EVSE

### 4.1.1 Shape and Size

The shape and size of the AC EVSE is shown in the figure below:

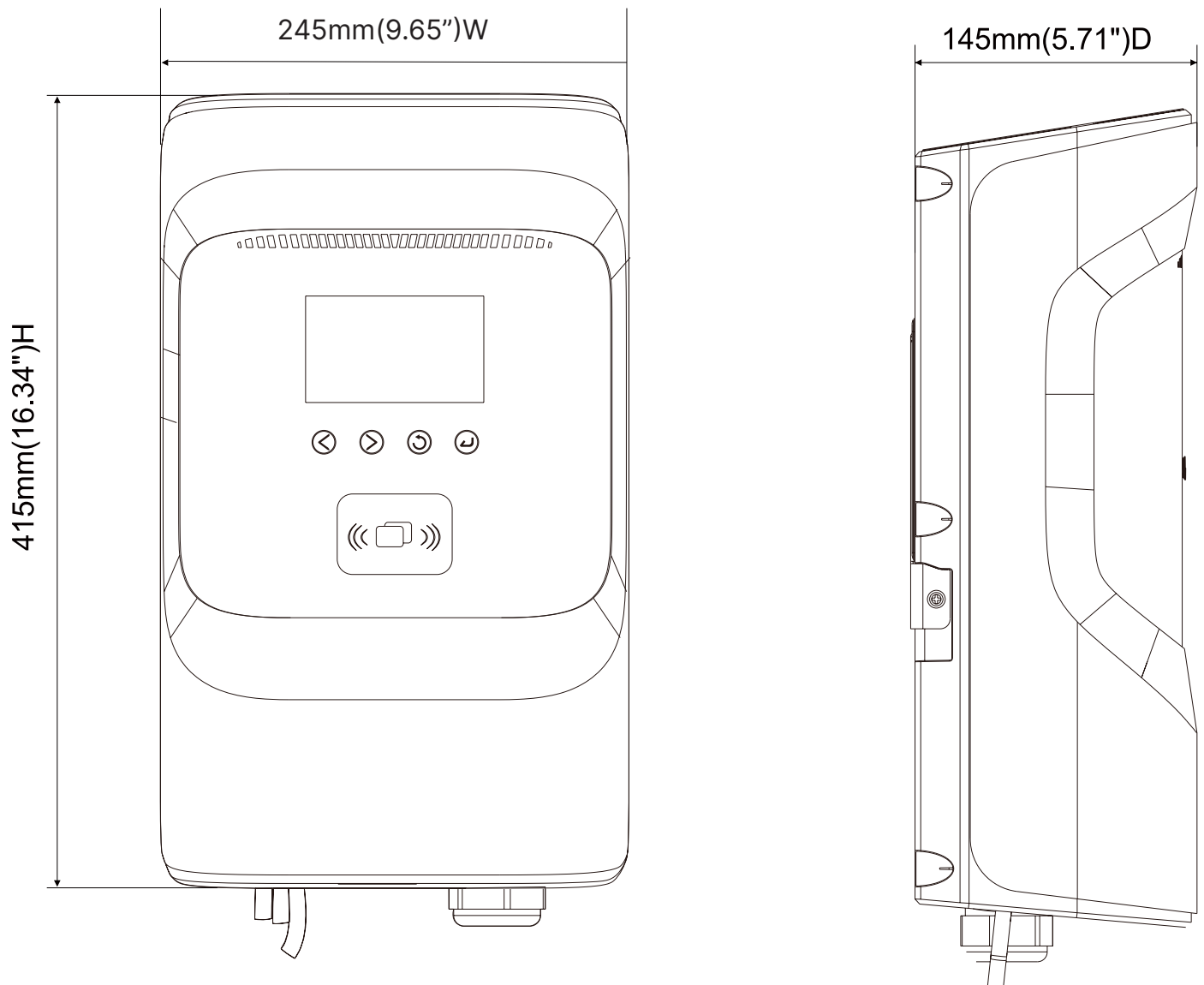

### 4.1.2 Block Diagram

The block diagram of EVSE is as follows:

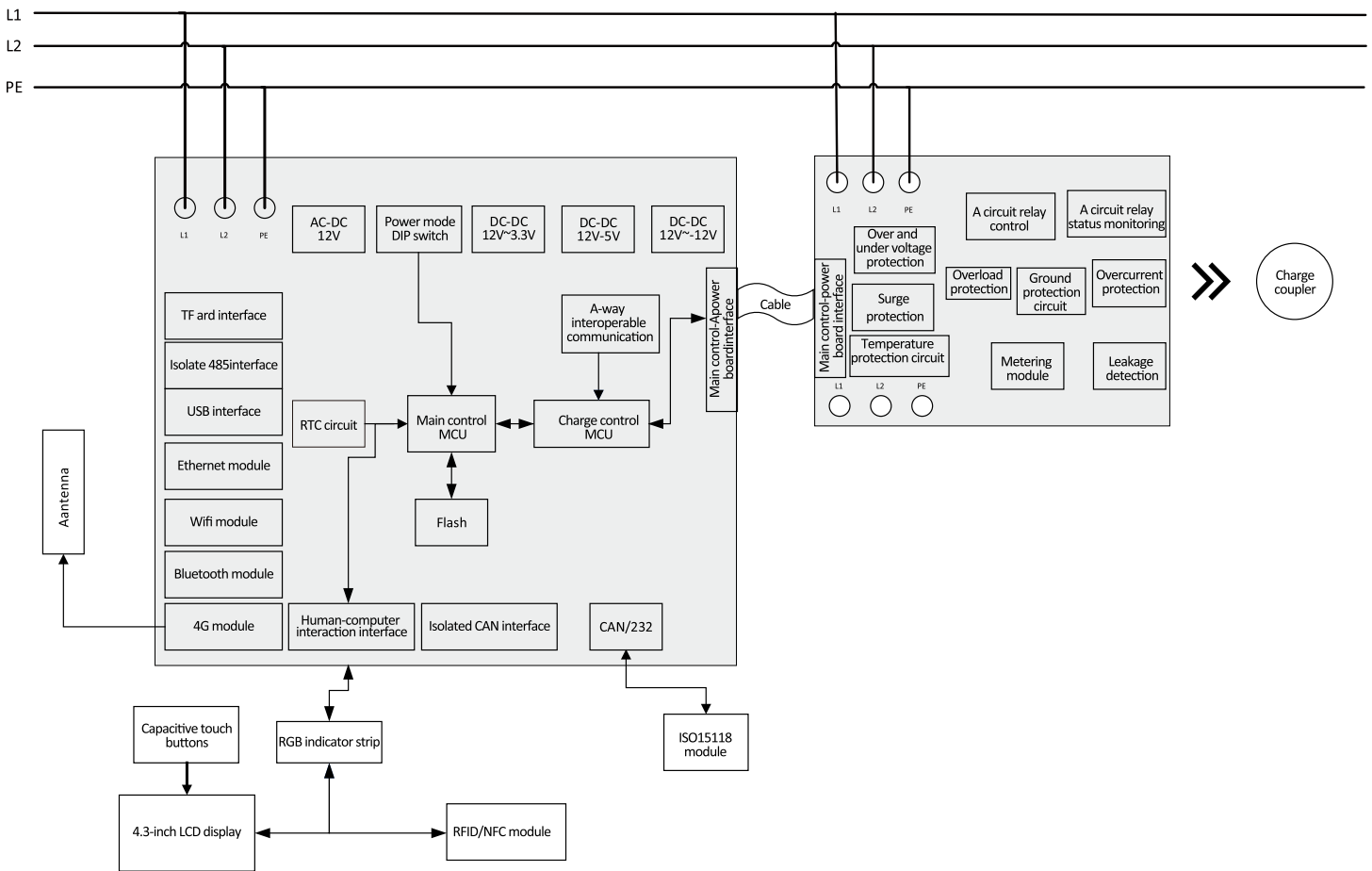

It is widely used in various household electric vehicle charging in North America, as well as parking lots, community garages and public electric vehicle charging places.

**4.2 Empty Seat**

- ▷ AC EVSE is equipped with an American standard car-side charging connector.
- ▷ When the EVSE is in standby mode, insert the car end charging connector into an empty seat to protect the car end charging connector.
- ▷ Use the mounting screws to fix this empty socket in place next to the EVSE.

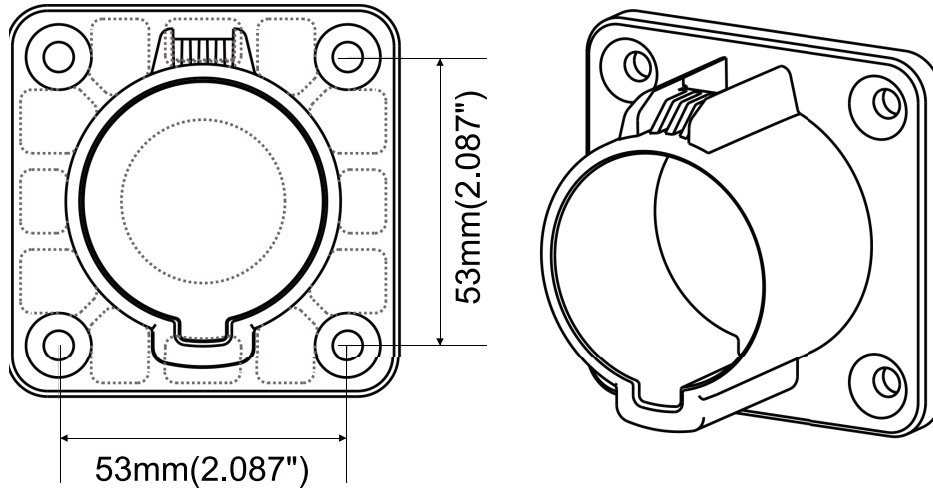

**4.3 Specification**

RD01 American Standard AC Charging Post Series							
Category	Specifications & Parameters						Option
	Model	Rated input/output voltage	Rated input current	Rated output current	Max power	Charge Coupler	
Power Specification	CTX-C32-240-1	Level 2, 208/240VAC 60Hz	32A	32A	7.68kW	SAE J1772 TYPE1 /32A	Optional
	CTX-C40-240-1	Level 2, 208/240VAC 60Hz	40A	40A	9.6kW	SAE J1772 TYPE1 /40A	Optional
	CTX-C48-240-1	Level 2, 208/240VAC 60Hz	48A	48A	11.52kW	SAE J1772 TYPE1 /48A	Optional

Power Wring +B8:H30	Hardwired via pigtail : L1/L2/GND	
Communication	4G cat.4	Optional
	WiFi 2.4G	Optional
	BLE 5.0	Optional
	RFID	Optional
	LAN (RJ-45)	Optional
	USB(type A)	Optional
	RS-485	Optional
	RS-232	Optional
	CAN	Optional
OCPP Version	OCPP 1.6J	
User Interface & Control	LCD Screen Size:4.3-inch /pixels resolution:800*480	
	Capacitive touch buttons	Optional
	Power Option Switch	
User Authentication	Swipe card	
	QR Code/APP	
	ISO 15118	Optional
Meter	Guideway power Meter Build-in	Optional
	On-board power meter	

Power Management	Load Balancing:Operating Stations		Optional
Memory	Flash Rom (16M-byte)		
	TF card memory expansion (No TF card)		
RealTime clock	Supercapacitor		
Protection Function	CCID20		
	Over Voltage Protection		
	Under Voltage Protection		
	Over-current protection		
	Over Load Protection		
	Ground Protection		
	Over-temp Protection		
	Surge Protection 6 kV @ 3,000A.		
Environmental	Fault self-test,		
	Enclosure Protection	Type 4, IK10	
	Operating Temperature	-30 ~ 50 °C	
	Storage Temperature	-40 ~ 75 °C	
	Humidity	Up to 95%, non-condensing	
	Altitude	≤2000m	
	Cooling Method	Natural Cooling	

Mechanical	Net Weight	14-16 lbs(32A)/ 19-20 lbs(40A)/ 22-23 lbs(48A)	
	EV Charger	D145mm(5.71") * W245mm(9.65") * H415mm(16.34")	
	Cable Length	18 Ft or Customization	
Regulation	Safety Regulations	ETL (UL2231,UL2594,UL1998,UL991)	
	Metering & Billing	CTEP	
	Energy Efficiency	Energy Star	
	Wireless Certificate	FCC,IC	
Warranty		2 years	

## 5. Operate

### 5.1 Switch

1. Check and make sure the mainboard power switch is off and that the fuse is there and installed. As shown below.

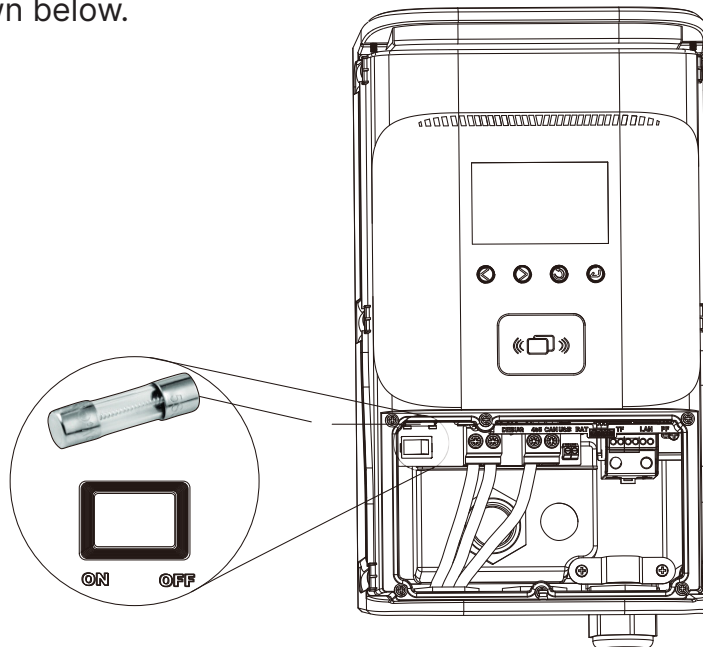

2. Turn off the power of this product, turn on the power switch of the mainboard; observe whether the boot interface of the product is normal.



**5.2 About the Interface**

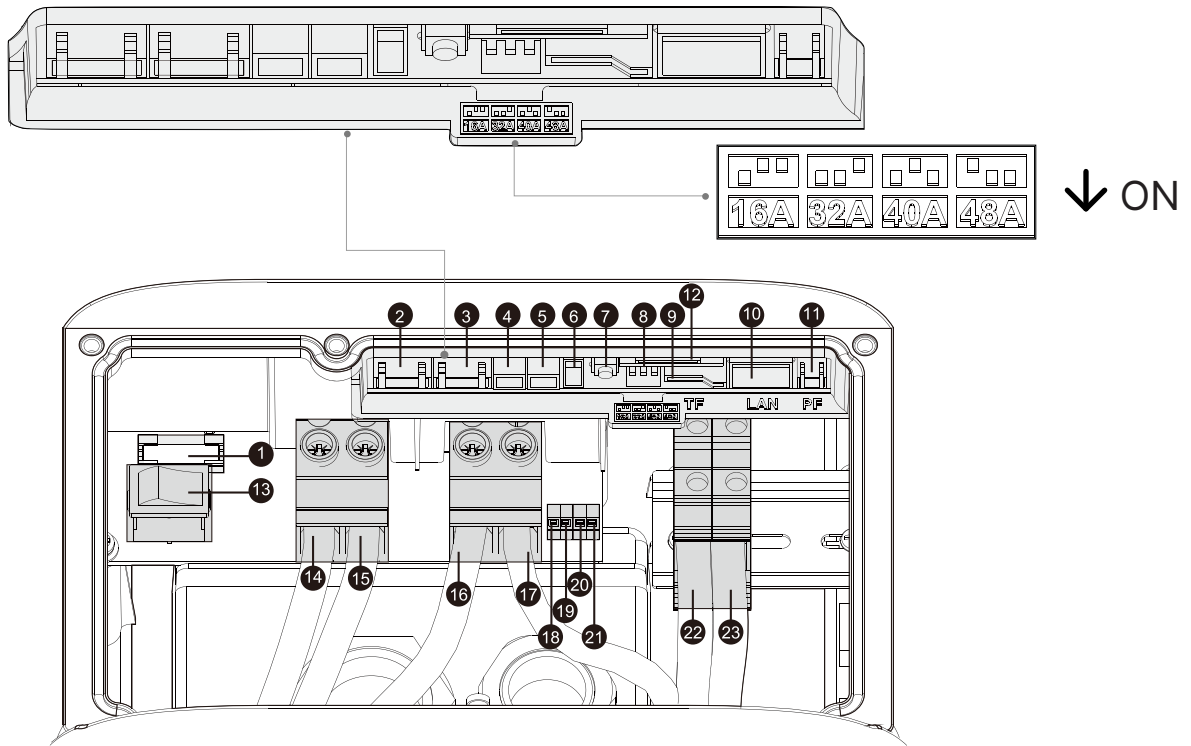

**Charging with dual pot version ECA-NC4803S updates the rated current according to the DIP switch status, no reboot required**

<input type="checkbox"/> <input type="checkbox"/>	<input type="checkbox"/> <input type="checkbox"/> <input type="checkbox"/>	<input type="checkbox"/> <input type="checkbox"/> <input type="checkbox"/>	<input type="checkbox"/> <input type="checkbox"/> <input type="checkbox"/>	<input type="checkbox"/> <input type="checkbox"/> <input type="checkbox"/>	<input type="checkbox"/> <input type="checkbox"/> <input type="checkbox"/>	<input type="checkbox"/> <input type="checkbox"/> <input type="checkbox"/>	<input type="checkbox"/> <input type="checkbox"/> <input type="checkbox"/>
16A	24A	32A	40A	48A	48A	48A	48A

Upstream Wiring Charging stations are considered continuous load devices (EVs draw maximum load for long durations); therefore, electrical branch circuits must be sized at 125% of the load for North American installations, in accordance with National Electric Code (NEC) requirements. (For other regions, refer to local code.) This means that for a maximum 48 A load at 208/240 V output to an electric vehicle, 60 A breakers are required.

Circuit breaker (amps)	Max output (amps)	Power output at 240 volts (kW)
60	48	11.5
50	40	9.6
40	32	7.6
30	24	5.7
20	16	3.8

NO	Name	functions	Specification
1	Fuse	Safety Protection	5*20, 250VAC, 10A
2	Debug serial port	Not open	
3	Download interface	Not open	
4	485 interface	Undeveloped	
5	CAN interface	Undeveloped	
6	USB interface	Undeveloped	
7	Coin cell battery	Clock power supply storage	CR1220
8	Dip switch Control	See picture 1 for setting method ,rated current setting	See picture 1 for setting method ,rated current setting
9	TF card holder	Undeveloped	Micro SD
10	Ethernet interface(RJ45)	Internet connection	100Mbps
11	PF pulse interface	Meter calibration	Optocoupler output, external pull-up resistor
12	<b>SIM card interface</b>	Internet connection	4G Micro SIM
13	Power switch	Power control	
14	Input L1	Power input	AC 208/240V 50/60Hz
15	<b>Input L2</b>	Power input	AC 208/240V 50/60Hz
16	Input GND	Power input	
17	Cable GND	Power output	
18	Reserved interface		
19	CP interface	Charging control guide	
20	RS485 interface A	Meter communication	
21	RS485interface B	Meter communication	
22	Cable L2	Power output	Depending on input
23	Cable L1	Power output	Depending on input



# 6. Features

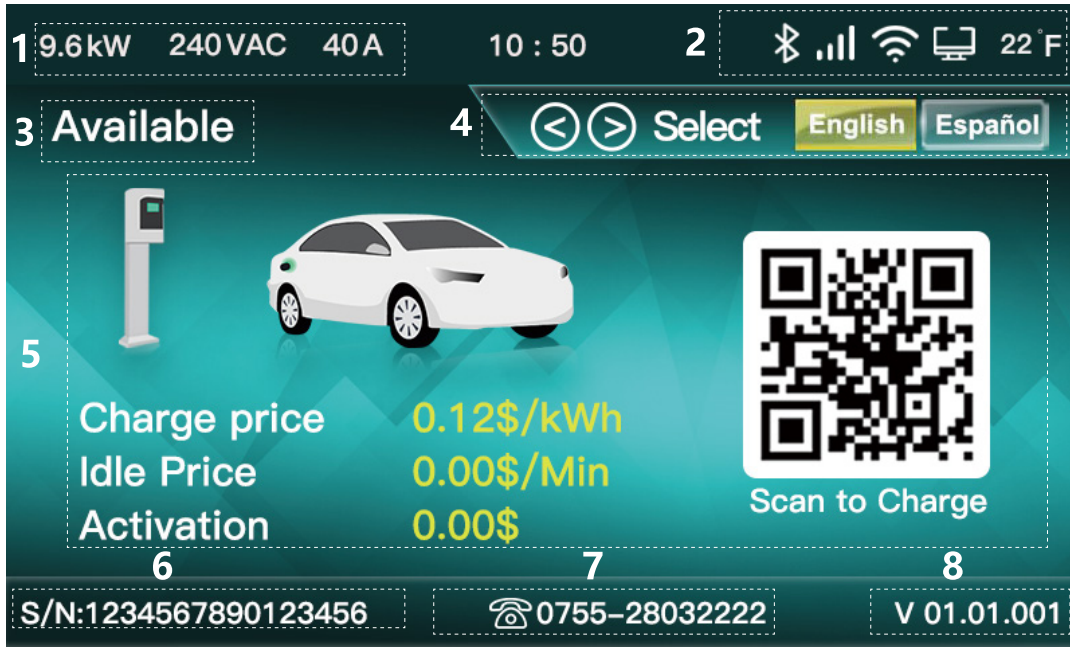

## 6.1 User Interface & Control

Take the ready state screen as an example to illustrate the meanings of common elements in the user interface interaction interface.

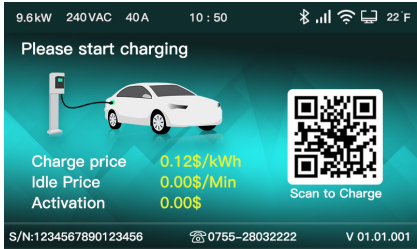

1. The electrical parameters are displayed in the upper left corner of the status bar, and the order from left to right is: charging power, voltage level, and rated current.  
The charging power is calculated by multiplying the grid voltage and the rated current. The voltage level is automatically detected as "208VAC" or "240VAC" when powering on. Rated current can be set by dial switch. For details on dial settings, please refer to the interface introduction and instructions. .
2. The upper right corner of the status bar displays network communication parameters. From left to right, there are Bluetooth, 4G, WIFI, Ethernet and Fahrenheit icons in the charger. The Bluetooth icon only appears when a Bluetooth module is installed. If the 4G module is not installed, it is a gray lowlight icon, and if the 4G module is installed normally, it is a white high-light icon. WIFI is a gray lowlight icon if not connected, and a white high-light icon when WIFI is properly set up and successfully connected . Ethernet is a gray low-light icon if communication with the router is not established, and white high-light icon when successfully established. The temperature inside the stake has a white highlighted icon, it's dynamic, and it's displayed in degrees Fahrenheit.
3. Status prompts vary as per different language and different status.
4. Language switching prompt is unique to the "Ready "screen . When you touch the button below , you can switch between English and Spanish . Currently , these are the only two languages available.
5. The main interface displays different content under each status.
6. Charging pile SN code -the unique code assigned at the time of delivery. The client can modify it through the server, but the uniqueness of the modification cannot be guaranteed.
7. After-sales service telephone.
8. Software Version No.

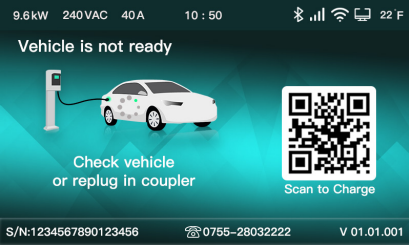
Status	Display Description	LED Description	Current Status Interactive Functions
Power on		No operation is recommended at this stage	No operation is recommended
Available		Green Always On	<ol style="list-style-type: none"> <li>1. Enter to the available page after the boot up finished;</li> <li>2. Touch the button to switch language;</li> <li>3. If there is no operation, the screen will dim automatically in 3 minutes;</li> <li>4. Screen can be wake up through either of following ways: touch button, insert the coupler, scan the code, tap the card, or other platform inter-action</li> </ol>
Start Charge (Insert the coupler and tap the card or app scan)		The green light is flashing fast.	<ol style="list-style-type: none"> <li>1. Start charging through RFID card, QR code scanning or APP, If charging coupler not plugged, it will notify for charging coupler plugging as shown left;</li> <li>2. The interface will stay for 1 minute, if the user does not insert the plug within 1 minute, it will return to the standby mode, the waiting time can be modified in the remote server.</li> </ol>
			<ol style="list-style-type: none"> <li>1. The user plugs in the coupler and jumps from standby to a page that prompts the user to initiate charging;</li> <li>2. This state will wait for the user to initiate charging;</li> <li>3. the user removes the charging coupler and returns to the standby page.</li> </ol>

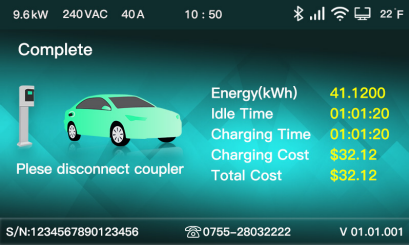
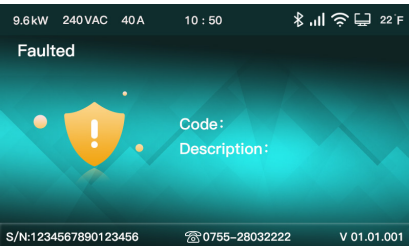
<p>Charging coupler plugged , but car not ready</p>		<p>blue light slow flash</p>	<ol style="list-style-type: none"> <li>1. After inserting the coupler and starting charging, the S2 switch inside the car is not closed, and it is not ready for charging, will jump to the car not ready page;</li> <li>2. Enter the charging page when the car is ready;</li> <li>3. If you unplug the charging cable at this time, the battery will return to the standby page.</li> </ol>
<p>Charging</p>		<p>Blue is always on</p>	<ol style="list-style-type: none"> <li>1. Enter the charging page after successfully starting charging;</li> <li>2. Actively end charging in this state (tap card, APP, platform remote control), will jump to the settlement interface;</li> <li>3. In this state, the tip of the coupler is loose, ( pull out the plug), will jump to the abnormal settlement interface.</li> </ol>
<p>Complete</p>		<p>Purple is always on</p>	<ol style="list-style-type: none"> <li>1. After the charging is completed normally, enter the charging completion settlement page;</li> <li>2. Unplug the plug and return to the standby screen.</li> </ol>
<p>Fault</p>		<p>Unrecoverable fault: red is always on Recoverable fault - slow flashing red</p>	<ol style="list-style-type: none"> <li>1. If an abnormality occurs in the non-charging state, jump to the fault prompt page;</li> <li>2. Recoverable faults: undervoltage, overvoltage, overtemperature, leakage, short circuit, overcurrent, ground fault;</li> <li>3. Non-recoverable faults: CP voltage abnormality, instrument failure, relay adhesion;</li> <li>4. If the fault is resolved, return to the interface before the fault was reported.</li> </ol>

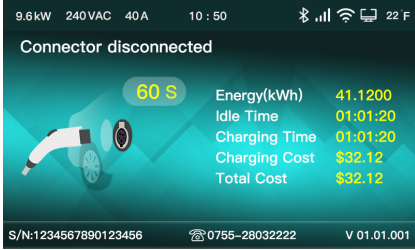
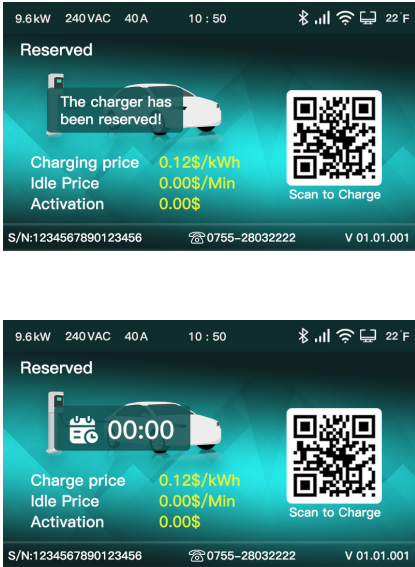
<p>Settlement Fault</p>		<p>Unrecoverable fault: steady red Recoverable fault - slow flashing red</p>	<ol style="list-style-type: none"> <li>1. If an abnormality occurs during charging, enter the fault settlement page;</li> <li>2. Recoverable faults: undervoltage, overvoltage, overtemperature, leakage, short circuit, overcurrent, ground fault, etc;</li> <li>3. Non-recoverable faults: CP voltage abnormality, instrument failure, relay adhesion, abnormality of functional modules, etc;</li> <li>4. Unplug the plug in this state, if the fault is not resolved, it will enter the fault prompt page; if the fault is resolved, it will return to the standby page.</li> </ol>
<p>Abnormal settlement</p>		<p>Purple slow flash</p>	<ol style="list-style-type: none"> <li>1. The plug is loose in the charging state, or is pulled out by external force to enter the settlement page of the connection and disconnection of the coupler head;</li> <li>2. Hold for 1 minute and return to the standby page;</li> <li>3. Re-plug the plug, you need to restart the charging process.</li> </ol>
<p>Reserved</p>		<p>Green slow flash</p>	<ol style="list-style-type: none"> <li>1. The user selects the electric pile in the APP, and enters the reserved page after operating the scheduled charging;</li> <li>2. Only reserved users can start charging;</li> <li>3. When non-reserved users start charging, it will prompt that the electric pile has been reserved;</li> <li>4. After the scheduled time is exceeded, if the customer is not present for use, it will automatically return to the standby page.</li> </ol>

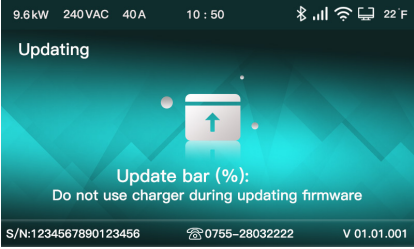
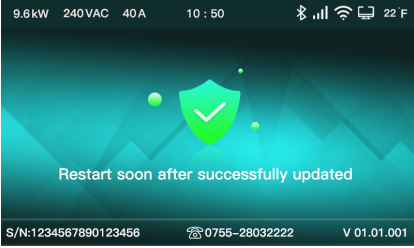
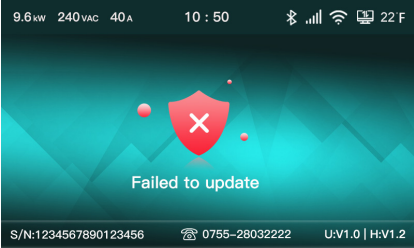
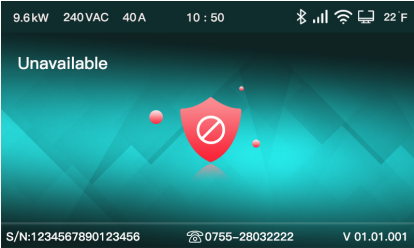

<p>System update</p>		<p>yellow slow flash</p>	<ol style="list-style-type: none"> <li>1. Perform remote OTA in standby state, in this state, there will be a percentage figure to show upgrading process . Download the firmware until complete, then it will confirm and check the content of the upgrade package;</li> <li>2. When the download is complete and the verification is successful, it will enter the upgrade success state;</li> <li>3. During the download process, if the network is disconnected or the verification fails after the download is complete, it will enter to upgrade failure state;</li> <li>4. After the upgrade is complete, the firmware version number in the bottom right corner will be updated.</li> </ol>
<p>System Update Succeeded</p>		<p>Yellow slow flash</p>	<ol style="list-style-type: none"> <li>1. After the firmware OTA update is successful, jump to the upgrade success page;</li> <li>2. After waiting for 10 seconds, turn on the power pile and restart.</li> </ol>
<p>System Update Failed</p>		<p>Yellow slow flash</p>	<ol style="list-style-type: none"> <li>1. If the upgrade fails, enter the upgrade failure prompt page;</li> <li>2. Wait for 10 seconds and return to the state before the firmware upgrade.</li> </ol>
<p>System Update Failed</p>		<p>Steady yellow</p>	<ol style="list-style-type: none"> <li>1. In the standby state, will enter to out of service state when receive " stop use"command from the server;</li> <li>2. Return to the standby state when receive " recover to use" command from server.</li> </ol>

## 6.2 Configure WiFi Network (Currently no APP)

### Internet configuration via WiFi and OCPP Authpass

Take the laptop configuration charger parameters as an example, the introduction is as follows. (The method of setting parameters with a mobile phone is similar and will not be repeated).

- Step 1: Connect to WiFi Hotspot.

Keep your laptop in a state where it can connect to a WIFI hotspot. Turn on the charger, find the hotspot- named “ECA-NH”, and connect to it without a password. (If you do not find a hotspot named “ECA-NH”, please restart the power of the charging station.

- Step 2: Log in to Settings.

Open a web browser, preferably Google Chrome or Microsoft Edge, and fill in the - IP address “ 192.168.4.1” in the browser’s address bar. Press the Enter key to enter the page of EVSE CONFIGURATION LOGIN. (Note: Microsoft IE browser cannot visit).

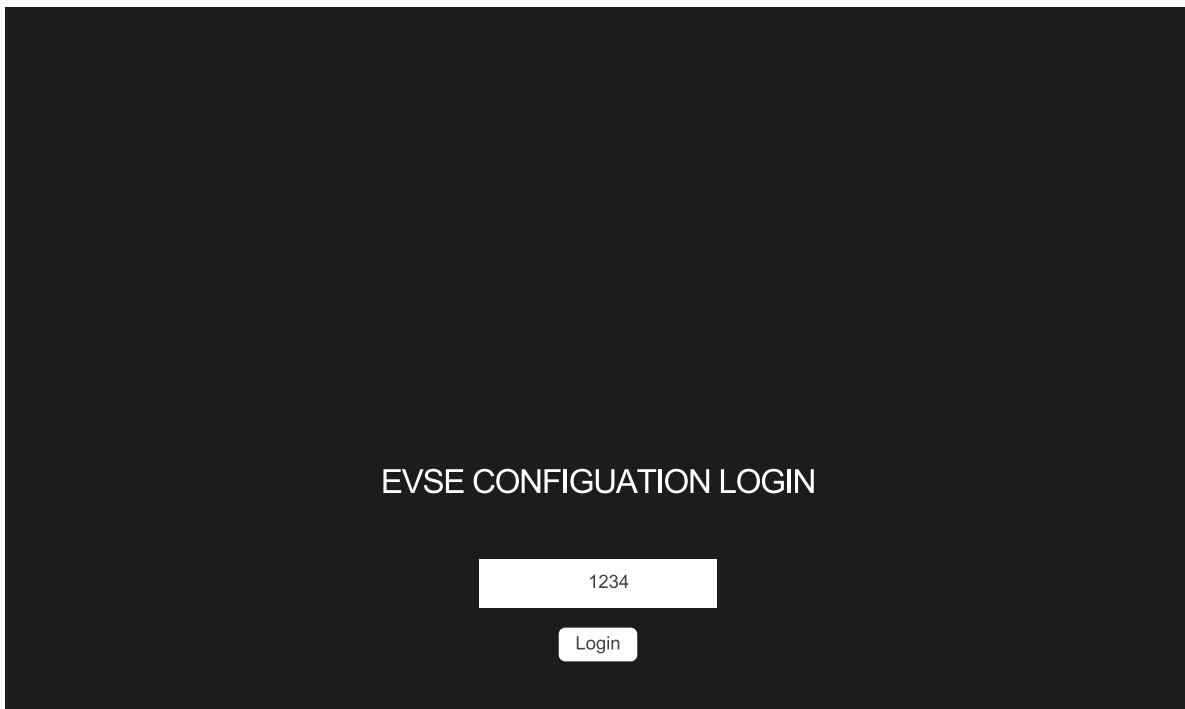

- Step 3: Configure Your EV Charger.

Fill in the default password from (PIN Code) the label on the panel charger. When you log in to this page for the first time, please change to a new login password, The new password can only be a 4-digit number.

Fill in the name of the hotspot and the password of your WIFI router on the web page, click the “SAVE” button to save the settings, and click the “RESTART” button to restart the charging pile to make the settings take effect.

Once it takes effect, the charging pile can be accessed through your WIFI router the Internet.



# EVSE CONFIGURATION

<h3 style="margin-top: 0;">Advanced Options</h3> <p>Serial Number: <input type="text" value="3885233376195"/></p> <p>OCPP Version: <input type="text" value="OCPP1.6-J"/></p> <p>OCPP Server: <input type="text" value="wss://centralsystem.ampup.io/ocpp"/></p> <p>OCPP AuthPass: <input type="text" value="0"/></p> <p>Connect Alternative Server: <input type="text" value="YES"/></p> <p>New password: <input type="text" value="Enter a new password of 1 to 9 characters"/></p> <p style="margin-left: 20px;"><input type="text" value="Enter password again"/></p> <h3 style="margin-top: 20px;">Network Setting</h3> <p>DHCP <input type="text" value="On"/></p> <p>Static IP: <input type="text" value="192.168.8.100"/></p> <p>Static Gateway: <input type="text" value="192.168.8.1"/></p> <p>Static Mask: <input type="text" value="255.255.255.0"/></p> <p>4G APN: <input type="text"/></p> <p>4G USER: <input type="text"/></p> <p>4G Password: <input type="text"/></p>	<h3 style="margin-top: 0;">User Options</h3> <p>WiFi SSID: <input type="text" value="Admin"/></p> <p>WiFi Password: <input type="text" value="12345678"/></p> <p>Plug and Play: <input type="text" value="Disable"/></p> <p>Share Current: <input type="text" value="0"/></p> <p>Modbus Address: <input type="text" value="0"/></p> <h3 style="margin-top: 20px;">Advanced Options</h3> <p>Serial Number: <input type="text" value="3885233376195"/></p> <p>OCPP Version: <input type="text" value="OCPP1.6-J"/></p> <p>OCPP Server: <input type="text" value="wss://centralsystem.ampup.io/ocpp"/></p> <p>OCPP AuthPass: <input type="text" value="0"/></p> <p>Connect Alternative Server: <input type="text" value="YES"/></p> <p>New password: <input type="text" value="Enter a new password of 1 to 9 characters"/></p> <p style="margin-left: 20px;"><input type="text" value="Enter password again"/></p> <h3 style="margin-top: 20px;">Network Setting</h3> <p>DHCP <input type="text" value="On"/></p> <p>Static IP: <input type="text" value="192.168.8.100"/></p> <p>Static Gateway: <input type="text" value="192.168.8.1"/></p> <p>Static Mask: <input type="text" value="255.255.255.0"/></p>
--	---

Fill in the name of the hotspot and the password of your WiFi router on the web page, click the "SAVE" button to save the settings, and click the "RESTART" button to restart the charging pile to make the settings take effect. Once it takes effect, the charging pile can be accessed through your WiFi router the Internet.

### 6.3 Operation Guide

#### 1. Charging Preparation:

A. Find the charging pile product in the idle standby state, park the car, turn off the vehicle, and make the electric car in a chargeable state.



B. If choose to use APP: You can download the APP according to the prompts, and register an account according to the prompts.



C. If choose to use an RFID card: Contact the operator to obtain an RFID card; the private pile is equipped with an RFID card in the box.



#### 2. To Connect The Charging Connector

Open the cover of the car charging socket, and connect the charging cable to the car socket stably. Make sure the connection is successful.



#### 3. Start Charging

A. Plug and charge  
The charging mode is configured as plug and charge, when step 2 is completed, the car is ready to start charging.



B. Tap card to start  
Put the RFID card close to the card-tapping area to start charging by tapping the card, and tap the card again during the charging process to end the charging.



C. APP start and stop  
Use the APP to scan the QR code to start charging, or connect to the electric pile through the Bluetooth of the mobile phone to start charging.



#### 4. Charging:

During the charging process, the charging pile screen will display the charging voltage, charging current, charging time,



**5. End Charging:**

A. Through charging, the car owner can take initiative to end the charging through tap RFID card or stop on APP or can be stopped through the car terminal for plug-and-play charging situation.



B. After the car is fully charged, it can automatically end the charging.

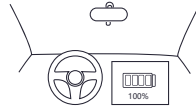

C. After the charging is completed, please pull out the charging coupler and put it back to the empty coupler-holder and hang the cables back on the hook.

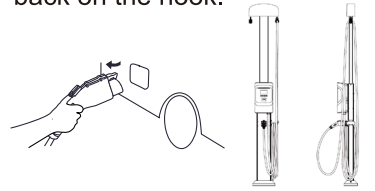

**6. Order Settlement:**

After the charging is completed, the display screen will display the charging power and charging cost. The order settlement will be completed on the APP or platform. Private piles and non-charging electric piles will display the charging power.

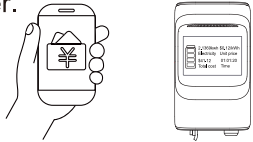

**7. Abnormal Situation:**

In any state, if there is abnormal prompt on the screen and the light bar, please stop charging and disconnect the charging cable from the socket on the car.

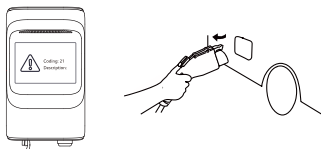

## 6.4 Troubleshooting

When a fault occurs, the charger will automatically protect. The fault information and processing methods are as follows.

Fault Code	Handling Method
Code 11: CP failure	Check that the adapter is properly connected to the electric vehicle, pull and plug the adapter and try charging again.
Code 13: Under voltage fault	Check that the input cable is reliably connected, that the parent grid is properly connected, and that the grid voltage is abnormal.
Code 14: Over voltage fault	Check whether the input cable is connected correctly; Whether the grid voltage is abnormal.
Code 15: Over temperature fault	Check whether the charging station is covered or installed in a high temperature environment.
Code 16: Meter failure	It is recommended to reboot on the power, there is a fault if you need to return to the factory.
Code 17: Leakage fault	Check whether the charging adapter and its cable are damaged or wet. Recover after pulling out the adapter.
Code 18: Short circuit fault	Check whether the charging adapter and its cables are damaged or wet.
Code 19: Over current fault	Check whether the charging adapter is correctly connected to the car, and check whether the on-board charger is normal.
Code 23: Relay sticking fault	The equipment is damaged and needs to be returned to the factory for repair.
Code 24: Leakagecurrent device failure	Users need to re-plug the coupler or contact the after-sales service.
Code 25: Ground fault	The charging pile is not grounded, so the circuit needs to be tested.

# 7 Install

## 7.1 Label

On the EVSE shell, there is a nameplate identifying the charger model and specifications, the content of which is as follows.

**WARNING**

For use with Electric Vehicles. Ventilation Not Required. To avoid a risk of fire or electric shock, do not use this device with an extension cord. This device is intended only for charging vehicles not requiring ventilation during charging.

THE SUITABILITY OF THE USE OF FLEXIBLE CORD IN ACCORDANCE WITH CE CODE, PART I.

**CAUTION**

To reduce the risk of electric shock, connect only to properly grounded outlets. Do not use this product if there is any damage to the unit. Risk of electric shock. Do not remove cover or attempt to open the enclosure. No user serviceable parts inside. Refer servicing to qualified service personnel.

**AVERTISSEMENT**

Pour utilisation avec des véhicules électriques. Aucune ventilation requise. Pour réduire le risque de choc électrique ou d'incendie, ne pas utiliser de rallonge avec cet appareil. Ce dispositif est destiné au chargement des véhicules ne nécessitant pas de ventilation au cours du chargement.

LA PERTINENCE DE L'UTILISATION DE CORDONS FLEXIBLES SELON LE CODE CE, PREMIERE PARTIE.

**ATTENTION**

Ne pas utiliser ce produit si l'appareil est endommagé. Risque de choc électrique. Ne pas retirer le couvercle ni essayer d'ouvrir le boîtier. Aucune pièce interne réparable par l'utilisateur. Confier tout travail d'entretien ou de réparation à un technicien qualifié. Pour réduire le risque de choc électrique, brancher sur une prise correctement mise à la terre.

**EV Charger**

Model: CTX-C48-240-1  
 Input/Output: 208/240VAC 50/60Hz  
 Max 48A Max 11.52kW





MMQ: 0.5kWh  
 Enclosure type: TYPE 4  
 Operating Temp: -30~50°C -22~122°F  
 Storage Temp: -40~75°C -40~167°F

SN: 2888535269720090  
 Date Code:  
 ECA2315RD020001

FOR USE WITH ELECTRIC VEHICLES. FOR INDOOR OR OUTDOOR USE. CAN ICES(A)/NMB(A)  
 IC: 27568-ECA02 FCC ID: 2APP2-ECA02  
 Contains FCC ID: 2A0XV-BR3602E-U2  
 Contains FCC ID: 2AFOS-WT32C3-SX Contains IC: 27481-WT32C3S1S2  
 Contains FCC ID: XMR202008EC25AFXD Contains IC: 10224A-022EC25AFXD

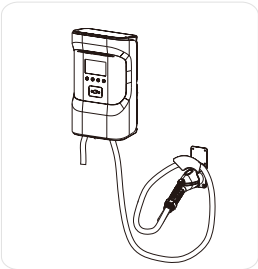
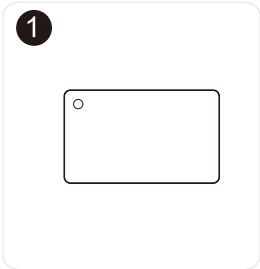
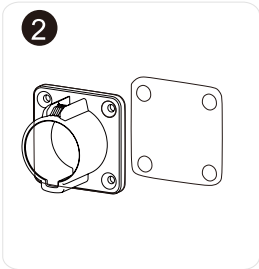
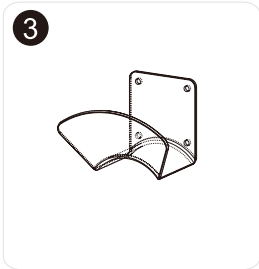
## 7.2 Package

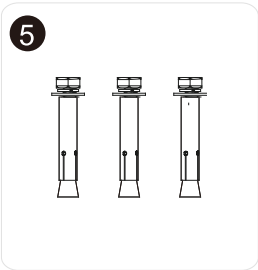
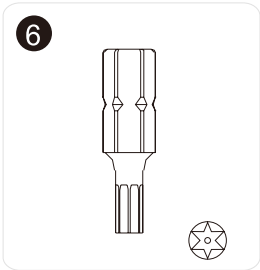
### 7.2.1 Packing List

- |  |   |   |  |   |
|--|---|---|--|---|
|  |  |  |  |  |
| AC charger   | RFID card<br>(2pcs)   | Coupler holder<br>(1pcs)  | Cord holder<br>(1pcs)  | Torx self-tapping<br>screws (8pcs)<br>Rubber Plug Expansion<br>Tube (8pcs)            |
|  |  |  |  |   |
| Expansion screw<br>(3pcs)  | Electric drill bit<br>(1pcs)  | 3-hole waterproof<br>connector<br>BN-M32-25 (1pcs)                                  | 3-hole waterproof<br>connector<br>BN-M25-18 (1pcs)                                   |   |

### 7.2.2 Check and Confirm

When unpacking, please confirm the following points carefully: According to the packing list, whether the accessories are complete.

Whether there is any damage during transportation.

Whether the model and specification on the nameplate of the machine are consistent with the order requirements.

- ▷ If any damaged or missing parts are found, please do not start the machine and contact the supplier as soon as possible.
- ▷ Please keep the box and packaging materials for 1 month for future disposal. Paper packaging is recyclable.

### 7.3 Preparation

In order to ensure the long-term stable operation of the product, it is recommended to avoid the following installation problems.

- ▷ This product is an electrical device. Handle with care and avoid severe vibration and shock.
- ▷ EVSE cannot be transported by dragging the charging connector and charging cable.
- ▷ EVSE cannot be used in extreme weather, especially when the ambient temperature is too low or too high, which will affect the use of EVSE.

It is recommended to install EVSE in a ventilated and cool place away from direct sunlight and rain. To ensure good ventilation, you should install the EVSE vertically with enough space. Installation tools Before installing AC EVSE, you should at least prepare the following tools.



Multimeter



Electric impact drill (D8mm+D6mm)

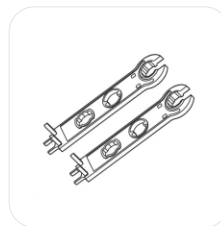

Wrench (10mm)

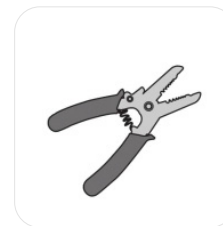

Wire strippers



AWG23-7 Tube terminal crimping pliers



Phillips screwdriver (D5mm)



Electric batch (with plum blossom hole T20.T25 bit)



Marker pen



Utility knife

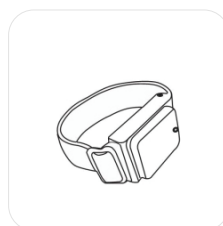

Anti-static bracelet



Heat coupler



Rubber hammer

## 7.4 Installation Steps

### Location Requirements

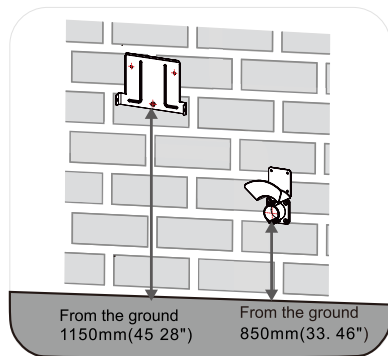
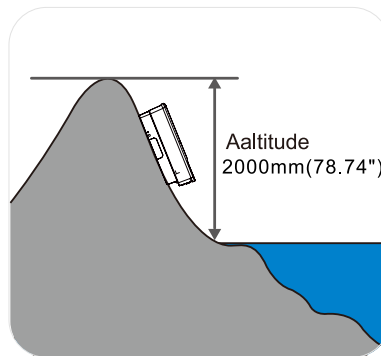
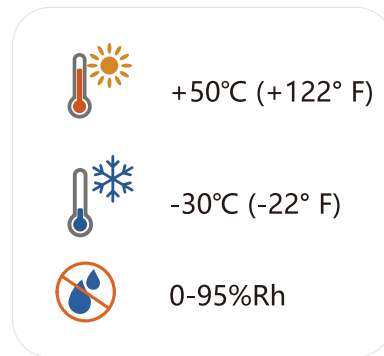
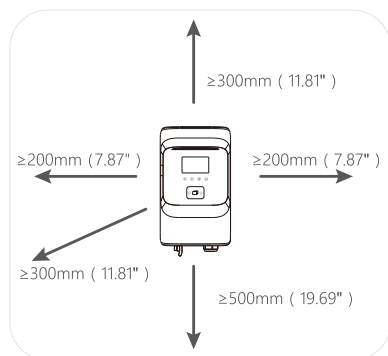
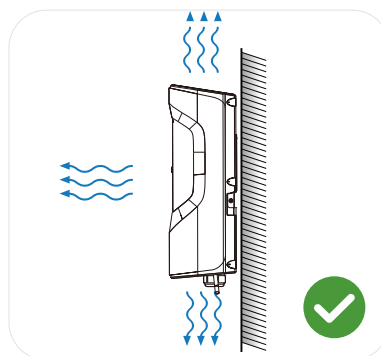
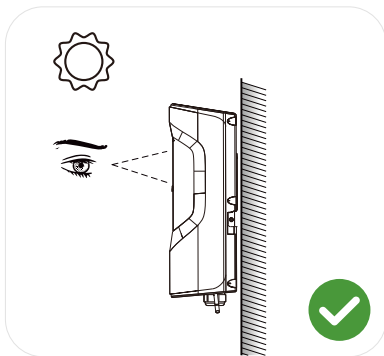
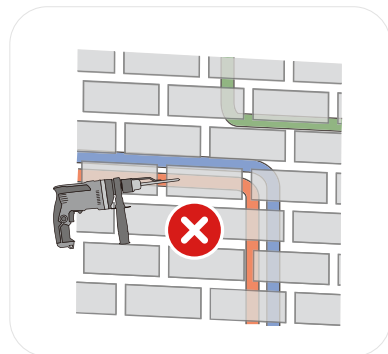

### Angle Requirements

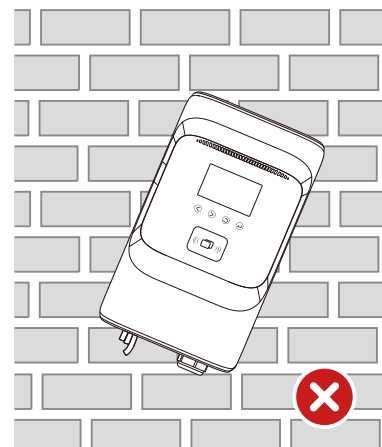
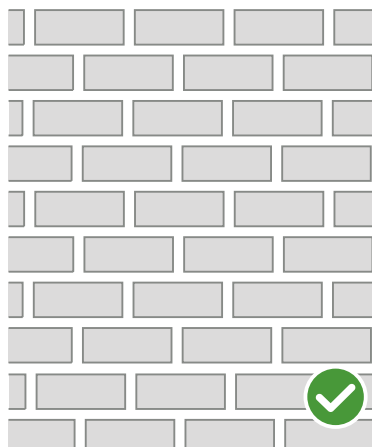
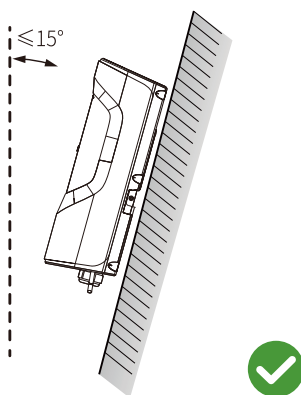

**Wall-mounted Installation Steps**

1 Install the wall-mounted version and trace holes on the wall.

2 Punch holes in the wall.

3 Install Wall Mounts, Hanging Plates and Empty Blocks.

4 Install piles on the wall.

5 Set screw.

6 Schematic diagram of the completion of the installation pile.

**Product Wiring**

1 Remove the decorative shell.

2 Remove the wiring cover.

3 Wiring.



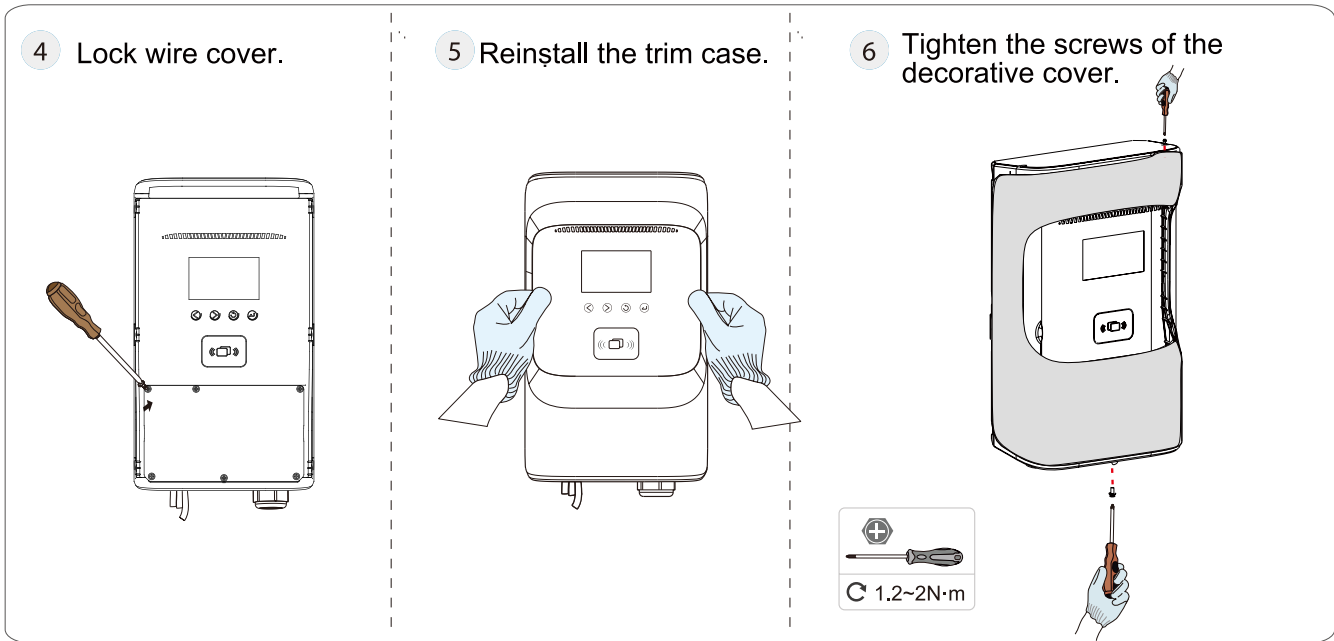

## 7.5 Grounding Instructions

### Grounding Instructions

This product must be connected to a grounded, metallic, permanent wiring system, or an equipment ground wire must be run with the circuit conductor and connected to the equipment ground terminal or conductor on the product.

The ground conductor must run with the circuit conductors and be connected to the equipment ground terminal or conductor on the product.

Input	L1 L2 PE
Output(SAEJ1772)	PE CP L2 L1
Output(NACS)	PE PP CP 12V NTC L2 L1
Crimp Terminal Specifications	E10-18 E6018 E1508 E10-12
Installation Tool Specifications	Diameter 3mm (0.1181") flat-blade screwdriver Diameter 5mm (0.1968") flat-blade screwdriver Diameter 5mm-6mm Phillips screwdriver
Input cable requirements	48A Wire gauge:L*2(8AWG)+PE(10AWG) or above
Wiring tightening torque	1.5~3N.m

## 7.6 Maintain

To ensure the long-term stable operation of the device, please perform regular (usually monthly) maintenance on the device according to the operating environment.

- (a) Equipment is maintained by professionals.
- (b) Check if the equipment is well grounded and safe.
- (c) Check whether there are potential safety hazards around the charging pile, such as whether there are high-temperature, corrosive, or flammable and explosive items near the charger.
- (d) Check whether the connection points of the input terminals are in good contact and whether there is any abnormality. Check other wiring points for looseness.

# Warranty

1. The scope of the warranty refers to the product itself.
2. The warranty period is 24 months. During the warranty period, if the product fails or is damaged under normal use (determined by the company's technicians), the company will repair it free of charge.
3. The starting time of the warranty period is the production date of the product.
4. Even within the warranty period, if the following conditions occur, a certain maintenance fee will be charged.

Equipment failure caused for not operate according to the user manual.

Equipment damage caused by fire, flood, abnormal voltage, etc.

Equipment damage caused by abnormal function of the product.

Equipment damage caused by the entry of foreign objects.

Equipment damage caused by other human-made external factors.

5. The service fee shall be calculated according to the actual cost. If there is any other contract, this contract shall prevail.
6. During the warranty period, please be sure to keep this card and show it to the maintenance personnel.
7. If you have any questions, please contact the agent or our company directly.



## For Both FCC & IC application:

This device complies with Part 15 of the FCC Rules / Industry Canada licence-exempt

RSS standard(s). Operation is subject to the following two conditions: (1) this device may not cause harmful interference, and (2) this device must accept any interference received, including interference that may cause undesired operation.

Le présent appareil est conforme aux CNR d'Industrie Canada applicables aux appareils radio exempts de licence. L'exploitation est autorisée aux deux conditions suivantes : (1) l'appareil ne doit pas produire de brouillage, et (2) l'utilisateur de l'appareil doit accepter tout brouillage radioélectrique subi, même si le brouillage est susceptible d'en compromettre le fonctionnement.

Changes or modifications not expressly approved by the party responsible for compliance could void the user's authority to operate the equipment.

This equipment has been tested and found to comply with the limits for a Class A digital device, pursuant to part 15 of the FCC Rules. These limits are designed to provide reasonable protection against harmful interference in a residential installation. This equipment generates uses and can radiate radio frequency energy and, if not installed and used in accordance with the instructions, may cause harmful interference to radio communications. However, there is no guarantee that interference will not occur in a part installation. If this equipment does cause harmful interference to radio or television reception, which can be determined by turning the equipment off and on, the user is encouraged to try to correct the interference by one or more of the following measures:

- Reorient or relocate the receiving antenna.
- Increase the separation between the equipment and receiver.
- Connect the equipment into an outlet on a circuit different from that to which the receiver is connected.
- Consult the dealer or an experienced radio/TV technician for help.

## MPE Requirements

To satisfy FCC / IC RF exposure requirements, a separation distance of 20 cm or more should be maintained between the antenna of this device and persons during device operation.

To ensure compliance, operations at closer than this distance is not recommended.

Les antennes installées doivent être situées de façon à ce que la population ne puisse y être exposée à une distance de moins de 20 cm. Installer les antennes de façon à ce que le personnel ne puisse être à moins de la position centrale de l'antenne.

La FCC des états-unis stipule que cet appareil doit être en tout temps éloigné d'au moins 20 cm des personnes pendant son fonctionnement.